

CASA

PALACIO

vive totalmente palacio®

THE

SOLU-

TION

CATÁLOGO
GENERAL
MOBILIARIO

Vers. 1.0

ISMOBEL

Grupo Ismobel

Somos muchos
y muy diferentes,
**pero nuestra
singularidad
es la diversidad.**

Una diversidad de países, culturas, costumbres,
personas, que están obligadas a coexistir.

Dentro de las empresas existen diferentes, áreas, perfiles,
equipos, proyectos y objetivos.
Cada uno con sus necesidades concretas.

Te proponemos un
viaje por la diversidad
**por un mundo
de posibilidades.**

WE ARE MANY AND SO DIFFERENT,
BUT DIVERSITY IS OUR UNIQUENESS.

A diversity of countries, cultures, customs, people,
that are forced to coexist.

In the companies there are different areas, profiles,
teams, projects and objectives. Each one with their
specific needs.

WE PROPOSE A TRIP THROUGH DIVERSITY.
IN A WORLD OF POSSIBILITIES.

NOUS SOMMES BEAUCOUP ET TRÈS DIFFÉRENTS MAIS
NOTRE SINGULARITÉ EST LA DIVERSITÉ.

Une diversité de pays, de cultures, de coutumes,
de personnes qui sont obligées à coexister.

À l'intérieur des entreprises ils existent différents, des áreas,
des profils, des équipes, des projets et des objectifs. Chacun
avec ses nécessités concrètes.

NOUS TE PROPOSONS UN VOYAGE PAR LA DIVERSITÉ.
PAR UN MONDE DE POSSIBILITÉS.

Más de 40 años aportando
soluciones integrales
a un sector en
constante evolución.

ISMOBEL cuenta con una infraestructura de 25.000m² situada estratégicamente con grandes ventajas logísticas y equipada con la tecnología necesaria para cada producto.

Un equipo de más de 100 personas, hace que ISMOBEL sea una empresa consolidada que aporta valor y conocimiento.



More than 40 years giving completed solutions to a sector in continuous evolution. ISMOBEL seating has a 25,000m² infrastructure located strategically with great logistics benefits and equipped with the necessary technology for each product.

A team of more than 100 people, makes jdm seating a consolidated company that provides value and knowledge.

**Our uniqueness,
our capacity for diversification.**



Plus de 40 ans en donnant des solutions intégrales à un secteur dans une évolution continue. ISMOBEL seating dispose d'une infrastructure de 25.000 M² située stratégiquement avec des grands avantages logistiques et équipée de la technologie nécessaire pour chaque produit.

Une équipe de plus de 100 personnes fait que jdm seating soit une entreprise consolidée qui apporte une valeur et une connaissance.

**Notre singularité,
notre capacité de diversification.**

NUESTRA SINGULARIDAD, NUESTRA CAPACIDAD DE DIVERSIFICACIÓN.

Entendemos esta diversidad
y trabajamos para dar respuesta
a nuevas necesidades.

We understand this diversity and we work to give answers to new needs.

Nous entendons cette diversité et travaillons pour donner la réponse à des nouvelles nécessités.





25.000 m²



ECODISEÑO ISO 14006:2011

ENTENDEMOS UN MUNDO MEJOR MÁS SOSTENIBLE, MÁS JUSTO.

y es por ello que desde hace tiempo apostamos por tomar medidas que minimicen nuestro impacto sobre el medio ambiente, y toda nuestra superficie que consta de **25.000 m² está cubierta de placas solares.**

and that is why for some time we have been committed to taking measures that minimize our impact on the environment, and our entire surface, which consists of 25.000 m², is covered with solar panels.

et c'est pourquoi depuis un certain temps, nous nous sommes engagés à prendre des mesures qui minimisent notre impact sur l'environnement, et toute notre surface, qui se compose de 25.000 m², est couverte de panneaux solaires.

ISMOBEL, reúne en este catálogo las colecciones que vienen a cubrir las necesidades del sector del equipamiento de oficina y puestos de trabajo. Colecciones independientes y complementarias a su vez. Un objetivo que se cumple gracias al trabajo en equipo del departamento de diseño, diseñadores, departamento comercial y conversaciones con clientes.

THE SOLUTION

ISMOBEL, reúne en este catálogo las colecciones que vienen a cubrir las necesidades del sector del equipamiento de oficina y puestos de trabajo. Colecciones independientes y complementarias a su vez. Un objetivo que se cumple gracias al trabajo en equipo del departamento de diseño, diseñadores, departamento comercial y conversaciones con clientes.

ISMOBEL, reúne en este catálogo las colecciones que vienen a cubrir las necesidades del sector del equipamiento de oficina y puestos de trabajo. Colecciones independientes y complementarias a su vez. Un objetivo que se cumple gracias al trabajo en equipo del departamento de diseño, diseñadores, departamento comercial y conversaciones con clientes.

recepciones

RECEPTION / RÉCEPTION



12
PUBLIC



28
maya

OPERATIVO

OPERATIVE / OPERATIVE



34
argos



76
maya



106
teSEO



122
DELFOs



130
eco



136
CERES



156
SKY



164
FEDRA

DIRECCIÓN

EXECUTIVE / DIRECTION



176
zen



192
nereO 2



204
nereO 3

BIBLIOTECA Y DIVISORIAS

LIBRARIES AND DIVIDERS / BIBLIOTHÈQUES ET SÉPARATEURS



226
BIBLOS



246
HORUS



270
PANEL

ALMACENAJE

STORAGE / STOCKAGE



282



recepciones

RECEPTION / RÉCEPTION

12 PUBLIC

28 maya



PUBLIC

RECEPTION & COMMUNITY

Designed by
SIGFRIDO BILBAO

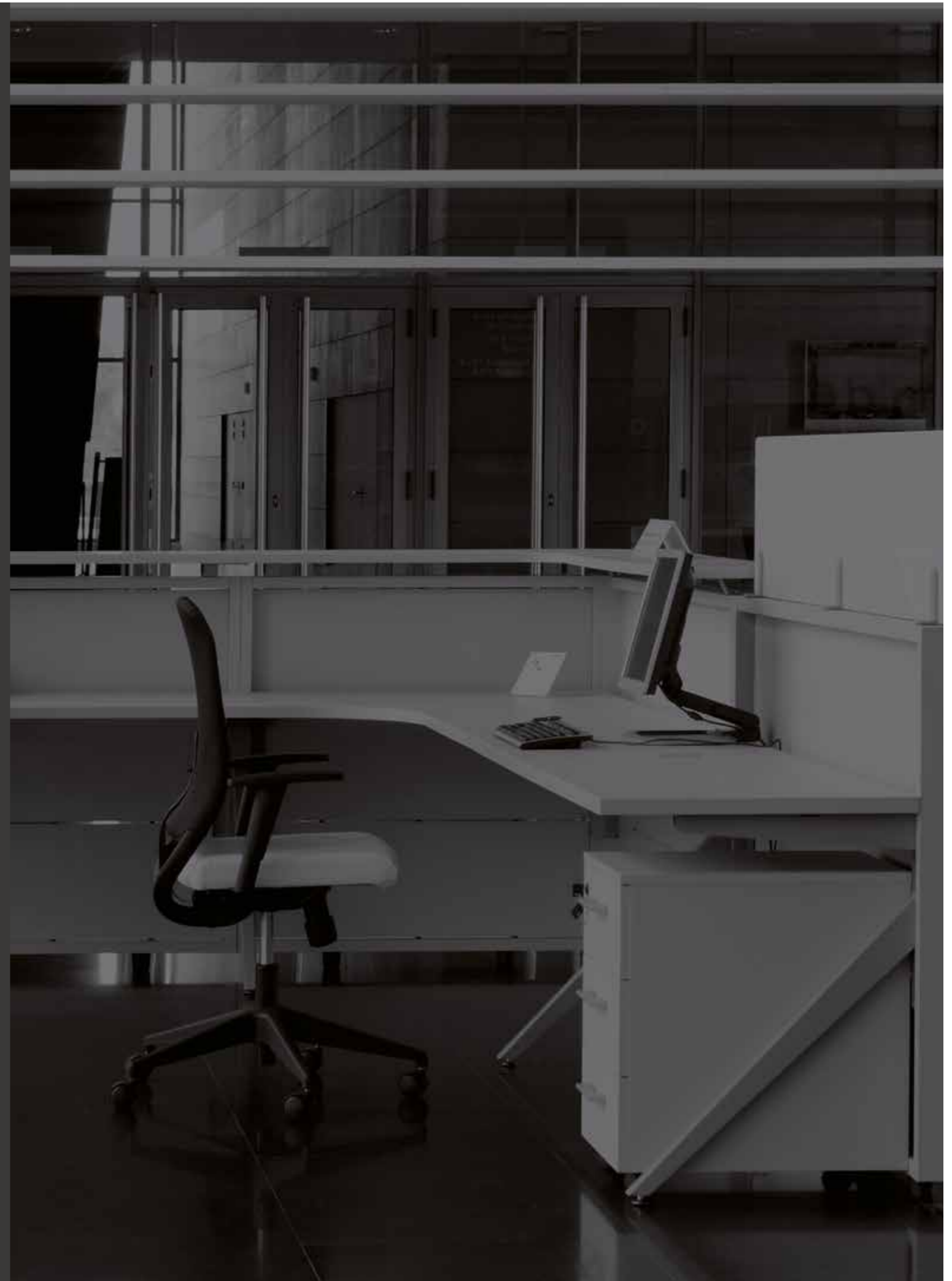

DESIGN BY:
SIGFRIDO BILBAO





















- Butacas Pares Fila 1 a 10
Stalls Even Row 1-10
- Butacas Fila 11 a 18
Stalls Row 11-18
- Salas de Reuniones 6,7,8 y 9
Conference Halls 6-7-8-9

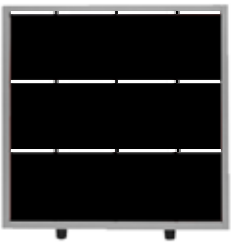

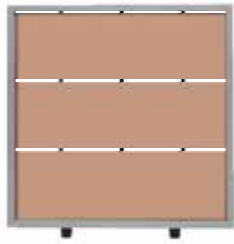
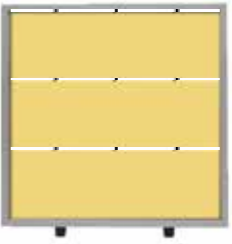

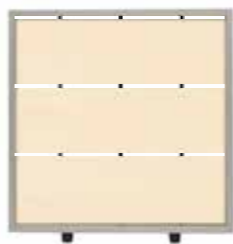

COLORES PANELES / Panel Finishes / Finitions Panneaux

				
BLANCO White / Blanc	GRIS Grey / Gris	ALUMINIO Aluminium / Aluminium	GRAFITO Grafhite / Anthracite	NEGRO Black / Noir
				
AZUL Blue / Bleu	NUDE Nude / Nude	AMARILLO Yellow / Jaune	VERDE Green / Vert	TERRACOTA Terracotta / Terre Cuite
				
ARCE Maple / Erable	ROBLE Oak / Poirier	HAYA Beech / Hêtre	BACO Baco / Baco	CEREZO Cherry / Mésisie



COLORES MARCOS / Frame Finishes / Finitions Cadres

BLANCO / White / Blanc

GRAFITO / Grafhite / Anthracite

ALUMINIO / Aluminium / Aluminium

COLORES ENCIMERAS / Top Finishes / Finitions Plateaux

					
NEGRO Black Noir	GRAFITO Grafhite Anthracite	GRIS Grey Gris	ALUMINIO Aluminium Aluminium	BLANCO White Blanc	CRISTAL Glass Vitrage
					
ARCE Maple Erable	BACO Baco Baco	HAYA Beech Hêtre	ROBLE Oak Poirier	CEREZO Cherry Mésisie	

PICTOS / PICTOGRAMS

 <table border="0"> <tr><td>A</td><td>B</td></tr> <tr><td>180</td><td>82</td></tr> <tr><td>160</td><td>82</td></tr> <tr><td>140</td><td>82</td></tr> <tr><td>120</td><td>82</td></tr> <tr><td>100</td><td>82</td></tr> <tr><td>80</td><td>82</td></tr> </table> <p>Mostrador recto Flat Counter Module droit</p>	A	B	180	82	160	82	140	82	120	82	100	82	80	82	 <table border="0"> <tr><td>B</td><td>A</td><td>B</td></tr> <tr><td>202</td><td>82</td><td>82</td></tr> <tr><td>182</td><td>82</td><td>82</td></tr> <tr><td>162</td><td>82</td><td>82</td></tr> <tr><td>202</td><td>82</td><td>82</td></tr> <tr><td>182</td><td>82</td><td>82</td></tr> <tr><td>162</td><td>82</td><td>82</td></tr> </table> <p>Mostrador giro interior 90° 90° inside return counter Module angle intérieur 90°</p>	B	A	B	202	82	82	182	82	82	162	82	82	202	82	82	182	82	82	162	82	82	 <table border="0"> <tr><td>A</td><td>B</td></tr> <tr><td>170</td><td>170</td></tr> </table> <p>Mostrador giro exterior 90° 90° outside return counter Module angle extérieur 90°</p>	A	B	170	170	 <table border="0"> <tr><td>A</td><td>h140</td><td>A</td><td>B</td></tr> <tr><td>180</td><td></td><td>180</td><td>70</td></tr> <tr><td>160</td><td></td><td>160</td><td>70</td></tr> <tr><td>140</td><td></td><td>140</td><td>70</td></tr> <tr><td>120</td><td></td><td>120</td><td>70</td></tr> <tr><td>100</td><td></td><td>100</td><td>70</td></tr> <tr><td>80</td><td></td><td>80</td><td>70</td></tr> </table> <p>Mostrador recto cristal vertical Flat counter with vertical glass Module droit vitré</p>	A	h140	A	B	180		180	70	160		160	70	140		140	70	120		120	70	100		100	70	80		80	70	 <table border="0"> <tr><td>A</td><td>B</td></tr> <tr><td>180</td><td>90</td></tr> <tr><td>160</td><td>90</td></tr> <tr><td>140</td><td>90</td></tr> <tr><td>120</td><td>90</td></tr> <tr><td>100</td><td>90</td></tr> <tr><td>80</td><td>90</td></tr> </table> <p>Mostrador recto discapacitados Flat counter for disabled Module droit handicapés</p>	A	B	180	90	160	90	140	90	120	90	100	90	80	90	 <table border="0"> <tr><td>A</td><td>B</td></tr> <tr><td>90</td><td>90</td></tr> </table> <p>Mostrador giro 90° discapacitados 90° return counter for disabled Module handicapés angle 90°</p>	A	B	90	90	 <table border="0"> <tr><td>A</td><td>B</td></tr> <tr><td>180</td><td>70</td></tr> <tr><td>160</td><td>70</td></tr> <tr><td>140</td><td>70</td></tr> <tr><td>120</td><td>70</td></tr> <tr><td>100</td><td>70</td></tr> <tr><td>80</td><td>70</td></tr> </table> <p>Mesa conferencias con panel Conference table with panel Table de conférence avec voile de fond</p>	A	B	180	70	160	70	140	70	120	70	100	70	80	70	 <table border="0"> <tr><td>A</td><td>B</td></tr> <tr><td>70</td><td>70</td></tr> </table> <p>Sobre giro/unión 90° conferencias 90° joining desk for conference tables Table de conférence angle/unión 90°</p>	A	B	70	70
A	B																																																																																																													
180	82																																																																																																													
160	82																																																																																																													
140	82																																																																																																													
120	82																																																																																																													
100	82																																																																																																													
80	82																																																																																																													
B	A	B																																																																																																												
202	82	82																																																																																																												
182	82	82																																																																																																												
162	82	82																																																																																																												
202	82	82																																																																																																												
182	82	82																																																																																																												
162	82	82																																																																																																												
A	B																																																																																																													
170	170																																																																																																													
A	h140	A	B																																																																																																											
180		180	70																																																																																																											
160		160	70																																																																																																											
140		140	70																																																																																																											
120		120	70																																																																																																											
100		100	70																																																																																																											
80		80	70																																																																																																											
A	B																																																																																																													
180	90																																																																																																													
160	90																																																																																																													
140	90																																																																																																													
120	90																																																																																																													
100	90																																																																																																													
80	90																																																																																																													
A	B																																																																																																													
90	90																																																																																																													
A	B																																																																																																													
180	70																																																																																																													
160	70																																																																																																													
140	70																																																																																																													
120	70																																																																																																													
100	70																																																																																																													
80	70																																																																																																													
A	B																																																																																																													
70	70																																																																																																													

maya

RECEPTION & COMMUNITY

Designed by
SIGFRIDO BILBAO



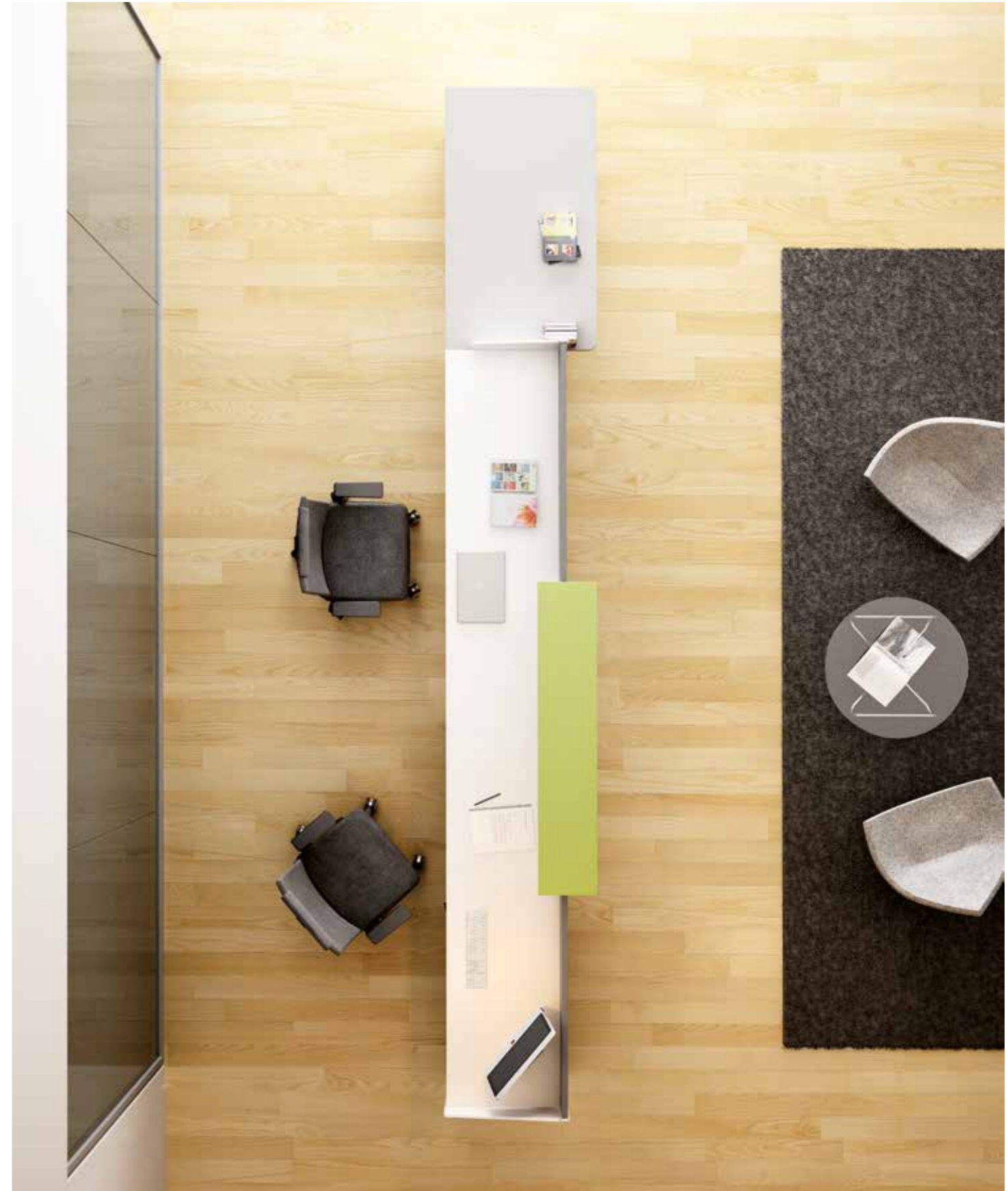

OPERATIVO

OPERATIVO / OPERATIVO

- 34 ARGOS
- 76 MAYA
- 106 TESEO
- 122 DELFOS
- 130 ECO
- 136 CERES
- 156 SKY
- 164 FEDRA

ARGOS

EQUIPAMIENTO INTEGRAL DE OFICINA

Designed by
SIGFRIDO BILBAO



ARGOS

EQUIPAMIENTO INTEGRAL DE OFICINA



Design by: SIGFRIDO BILBAO

ARGOS, UNA COLECCIÓN QUE SE ADAPTA A LA DIVERSIDAD DE NECESIDADES DE LOS LUGARES DE TRABAJO ACTUALES.

Su diversidad de formas y la particularidad del diseño de la pata, nos permite resolver el equipamiento para zonas de Dirección, puestos Operativos y Multipuesto, así como zonas de reunión, estas últimas totalmente integradas con puestos operativos.

ARGOS, A COLLECTION WHICH ADAPTS TO THE DIVER SITY OF THE NEEDS OF THE CURRENT WORK PLACES.

Its diversity of shapes and the particularity of the design of the leg allows us to solve the equipment for Management areas, task desks, workstations as well as meeting areas, this one fully integrated with task desks.

ARGOS, EST UNE COLLECTION QUE L'ON ADAPTE À LA DIVERSITÉ DE NÉCESSITÉS D'ACTUELS LIEUX DE TRAVAIL.

Sa diversité de formes et la particularité du dessin de la patte nous permet de résoudre l'équipement pour des zones de Direction, de postes Opérationnels et de Multiposte, ainsi que des zones de réunion, totalement intégrées avec postes opérationnels.



UP & DOWN

Las diferentes necesidades se dividen en diferentes espacios,
diversas soluciones para cubrir esas necesidades.
PUESTOS OPERATIVOS MULTIDISCIPLINARES.

The different needs are divided into
different spaces, different solutions to
meet those needs.

MULTIDISCIPLINARY TASK DESKS.

Différents besoins sont divisés en
différents espaces, il y a diverses
solutions pour couvrir ces nécessités.

DES POSTES OPÉRATIONNELS
MULTIDISCIPLINAIRES.





VERSATILITY

Este modelo presenta una gran versatilidad. La facilidad de generar composiciones diferentes permite adaptarnos a necesidades muy concretas.

This model presents great versatility. The facility to make different compositions allows us to adapt to very specific needs.

Ce modèle présente une grande versatilité. La facilité de générer différentes compositions permet de nous adapter aux nécessités très concrètes.

YOU & ME & US

Los espacios polivalentes son cada vez más necesarios en nuestros lugares de trabajo. La individualidad y la necesidad de reunirse, son acciones que determinan nuestro día a día.

ADAPTABILIDAD A LAS NECESIDADES

Multipurpose spaces are increasingly necessary in our workplaces. The individuality, and the need to meet are actions that determine our day to day.

ADAPTABILITY TO THE NEEDS

Les espaces polyvalents sont de plus en plus nécessaires dans nos lieux de travail. L'individualité, et la nécessité de se réunir ce sont des actions qu'ils déterminent le notre au jour le jour.

UNE ADAPTABILITÉ AUX NÉCESSITÉS



PLAY & STOP

El espacio en las oficinas tiene dos momentos, cuando trabajamos en él y cuando finalizamos la jornada. Es por eso que la modularidad de ARGOS nos permita redefinir el espacio en ambas situaciones.

The space in the offices has two moments, when we work on it and when we finish the day. That is why the modularity of ARGOS allows us to redefine the space in both situations.

L'espace dans les bureaux a deux moments, quand nous travaillons dans lui et quand nous finissons la journée. C'est par cela que la modularité ARGOS nous permet de redéfinir l'espace dans les deux situations.





ELEGANCE

La calidad de un espacio es importante y determinante en muchos casos para generar un ambiente de trabajo agradable. ARGOS nos brinda la posibilidad de mimetizarnos en ese entorno.

The quality of a space is important and determinant in many cases to generate a pleasant work environment. ARGOS offers us the possibility of mimicking ourselves in that environment.

La qualité d'un espace est important et déterminant dans beaucoup de cas pour générer une atmosphère de travail agréable. ARGOS nous offre la possibilité de nous imiter dans cet environnement.





PRIVACY

En la actualidad la privacidad es más importante que nunca. La modularidad y los sistemas de separación permiten la privacidad sin perder el contacto y la posibilidad de comunicación con otras personas.

Nowadays privacy is more important than ever. Modularity and separation systems allow privacy without losing contact and the possibility of communication with other people.

Actuellement la confidentialité est plus importante que jamais. La modularité et les systèmes de séparation permettent la confidentialité sans perdre le contact et la possibilité de communication avec d'autres personnes.



SINGULAR DIVERSITY

Dentro de la diversidad y la variedad, hay que prestar especial importancia a la singularidad de cada uno, de cada proyecto, de cada espacio.

Within diversity and variety, we must pay special importance to the uniqueness of each one, of each project, of each space.

Dans la diversité et la variété, il faut donner une importance spéciale à la singularité de chacun, de chaque projet, de chaque Espace.



Being part of a team is increasingly necessary to solve the challenges of day to day, but without losing the privacy of each of its members.

Faire partie d'une équipe est de plus en plus nécessaire pour résoudre les défis d'au jour le jour, mais sans perdre une confidentialité de chacun de ses membres.

COLLECTIVE PRIVACY

Formar parte de un equipo es cada vez más necesario para resolver los retos del día a día, pero sin perder la privacidad de cada uno de sus miembros.





ONLY & TOGETHER

Cada proyecto empresarial o personal tiene unas necesidades particulares. Con la modularidad se consiguen espacios individuales o colectivos.



Each business or personal project has particular needs. Modularity, give us individual or collective.

Chaque projet patronal ou personnel ils ont quelques nécessités particulières. Avec la modularité des espaces individuels ou collectifs sont obtenus.



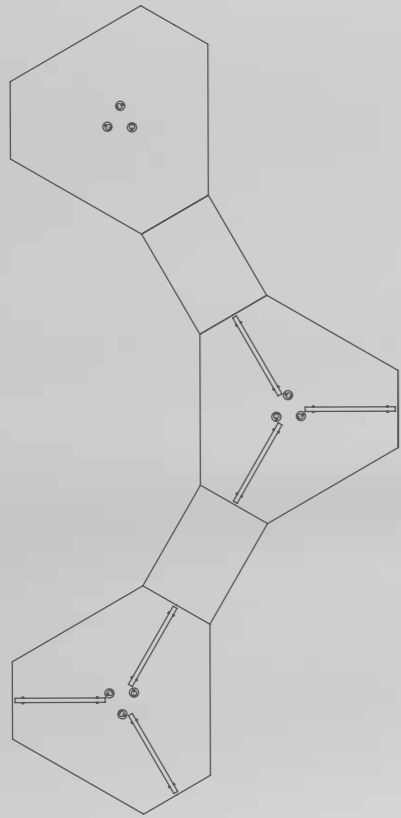



MEETING & WORKING

Alternar los momentos de trabajo con los de compartir información y proyectos con el equipo, son cada vez más habituales. Estas situaciones generan necesidades en las que ARGOS da respuesta a ambas demandas.

Alternating working moments with those of sharing information and projects with the team are becoming more common. These situations generate needs in which ARGOS responds to both demands.

Alternar los momentos de trabajo con los de compartir información y proyectos con el equipo son de más en más habituales. Estas situaciones generan las necesidades en las que ARGOS da respuesta a ambas demandas.

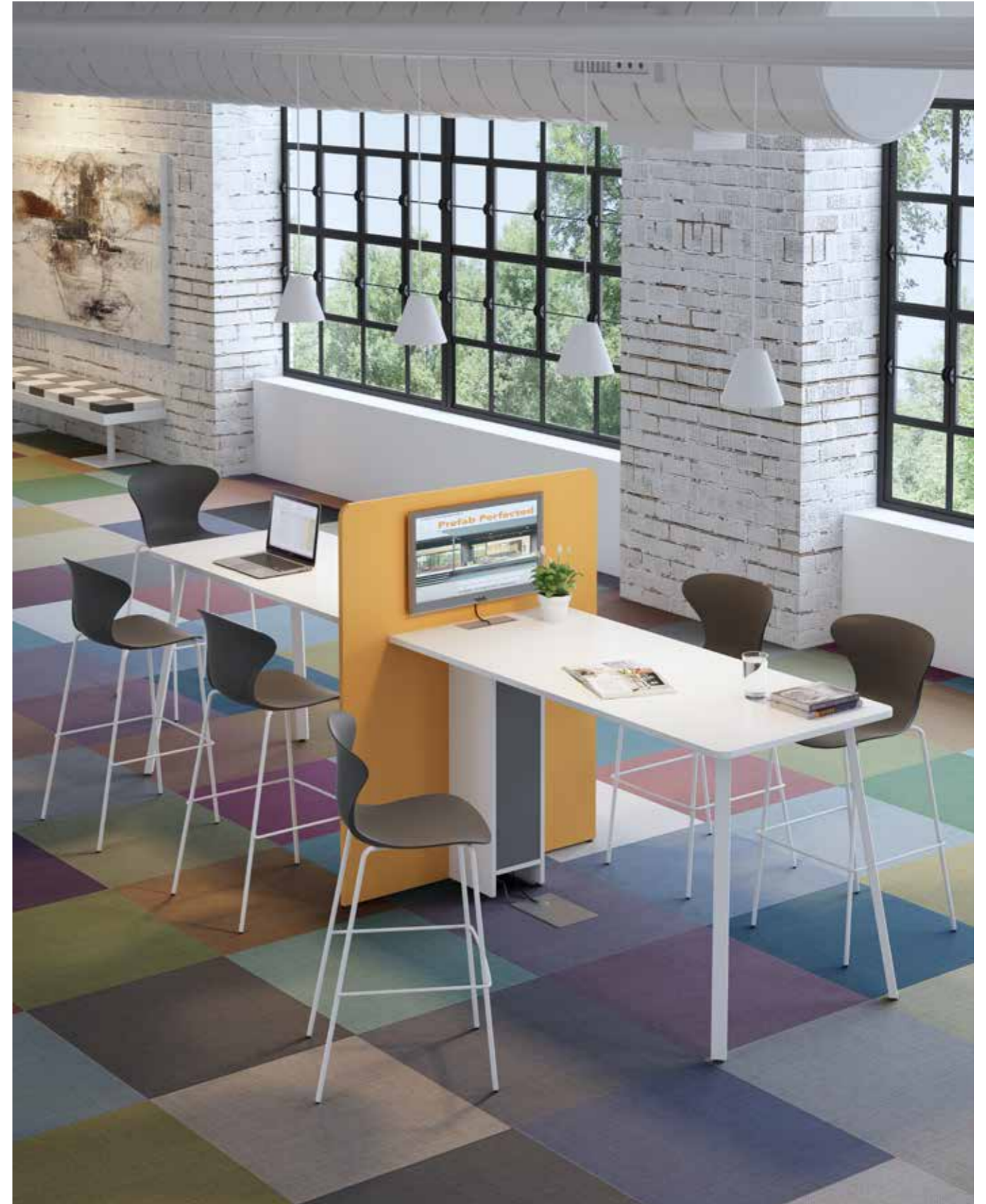



LIBRARY

Espacios polivalentes para informarse, reunirse, estudiar, exigen de soluciones inteligentes para adaptarse a cada situación y a la demanda del usuario.

Multipurpose spaces for information, meeting, studying, demand intelligent solutions to adapt to each situation and user demand.

Des espaces polyvalents pour être informé, pour se réunir, étudier, ils exigent des solutions intelligentes pour s'adapter à chaque situation et à la demande de l'utilisateur.









The storage spaces are an indispensable complement in the work spaces. The modularity and accessibility to the information or to the elements that we keep is important. ARGOS is a system that allows you to modularize and concatenate your different models.

Les espaces de stockage sont un complément indispensable dans les espaces de travail. La modularité et l'accessibilité à l'information ou aux éléments que nous gardons c'est important. ARGOS est un système qui permet modulariser et enchaîner ses différents modèles.



IN & OUT

Los espacios de almacenaje son un complemento indispensable en los lugares de trabajo. La modularidad y accesibilidad a la información o a los elementos que guardamos es importante. ARGOS es un sistema que permite modularizar y concatenar sus diferentes modelos.



ACABADOS

FINISHINGS / FINITIONS

MELAMINAS

MELAMINE / MÉLAMINES



NEGRO
BLACK
NOIR

GRAFITO
GRAPHITE
ANTHRACITE

GRIS
GREY
GRIS

ALUMINIO
ALUMINIUM
ALUMINIUM

BLANCO
WHITE
BLANC



ARCE
MAPLE
ERABLE

BACO
BACO
BACO

HAYA
BEECH
HÊTRE

ROBLE
OAK
POIRIER

CEREZO
CHERRY
MÉRISIE

Los colores de este catálogo son orientativos, la percepción de los mismos puede variar respecto al original.

The colours of this catalogue are reference, the perception of the same can vary with respect to the original one.

Les couleurs figurant sur le catalogue sont indicatifs, ils peuvent varier para rapport à l'original.

ELEMENTOS VERTICALES

VERTICAL ELEMENTS / ÉLÉMENTS VERTICAUX



AZUL
BLUE
BLEU

NUDE
NUDE
NUDE

VERDE
GREEN
VERT



AMARILLO
YELLOW
JAUNE

TERRACOTA
TERRACOTTA
TERRE CUITE

ACABADOS PATAS

LEG FINISH / FINITION DES JAMBES

TAPAS

TOPS / TABLETTES



NEGRO
BLACK
NOIR

ALUMINIO
ALUMINIUM
ALUMINIUM

BLANCO
WHITE
BLANC

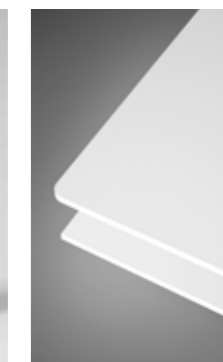

CANTO RECTO
STRAIGHT EDGE
BORD DROIT

CANTO CURVO
CURVED EDGE
BORD COURBE

MADERA
WOOD
MADÈRE

maya

EQUIPAMIENTO INTEGRAL DE OFICINA

Designed by
SIGFRIDO BILBAO





Design by: SIGFRIDO BILBAO

DIRECCIÓN
MANAGEMENT / DIRECTION

OPERATIVO
OPERATIVE / OPÉRATIVE

BENCH
BENCH / BENCH

REUNIÓN FORMACIÓN
MEETING TRAINING / RÉUNION FORMATION

BIBLIOTECA
LYBRARY / BIBLIOTHÈQUE

ACABADOS
FINISHINGS / FINITIONS

TÉCNICO
TECHNICAL / TECHNIQUE

**SOLUCIONES OPERATIVAS,
MÁXIMO APROVECHAMIENTO
DE ESPACIOS, RACIONALIDAD
DE ARCHIVOS.**

OPERATIVE SOLUTIONS,
OPTIMAL USE OF THE SPACE,
RATIONAL FILING CABINET

SOLUTIONS OPÉRATIONNELLES,
OPTIMISATION DES VOLUMES,
RATIONALISATION DES
RANGEMENTS

DIRECCIÓN

MANAGEMENT / DIRECTION







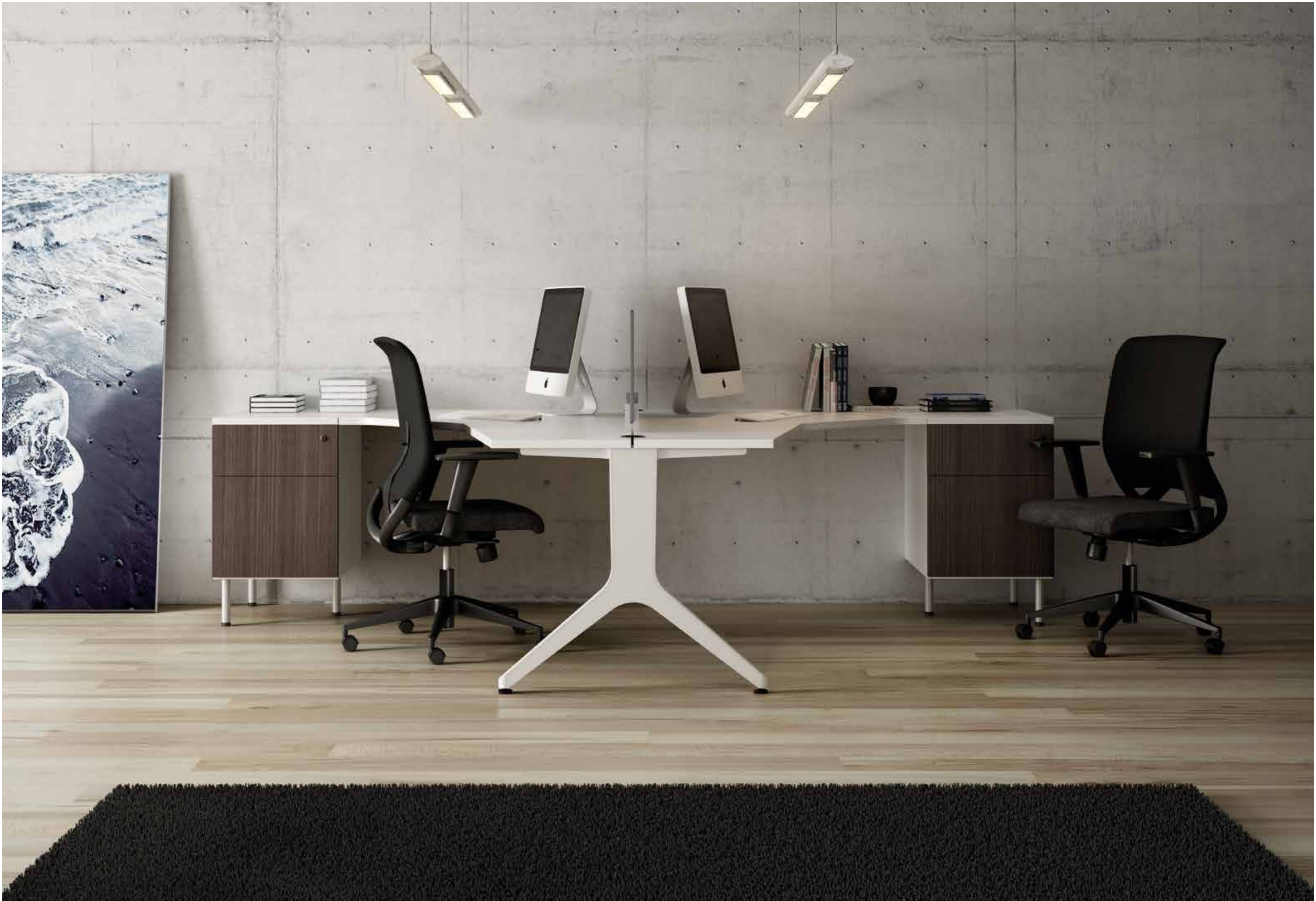









BENCH

BENCH / BENCH





REUNIÓN FORMACIÓN

MEETING TRAINING / RÉUNION FORMATION



BIBLIOTECA

LIBRARY / BIBLIOTHÈQUE



ACABADOS

FINISHINGS / FINITIONS

Los colores de este catálogo son orientativos, la percepción de los mismos puede variar respecto al original.

The colours of this catalogue are reference, the perception of the same can vary with respect to the original one.

Les couleurs figurant sur le catalogue sont indicatifs, ils peuvent varier para rapport à l'original.



NEGRO BLACK / NOIR
GRAFITO GRAPHITE ANTHRACITE
GRIS GREY GRIS
ALUMINIO ALUMINIUM ALUMINIUM
BLANCO WHITE / BLANC



ARCE MAPLE ERABLE
BACO BACO BACO
HAYA BEECH HÊTRE



ROBLE OAK POIRIER
CEREZO CHERRY MERISIE

ELEMENTOS VERTICALES VERTICAL ELEMENTS / ÉLÉMENTS VERTICAUX



AZUL BLUE BLEU
NUDE NUDE NUDE
VERDE GREEN VERT



AMARILLO YELLOW JAUNE
TERRACOTA TERRACOTTA TERRE CUITE

ACABADOS METÁLICOS METAL FINISHING / METAL FINITIONS



NEGRO BLACK / NOIR
ALUMINIO ALUMINIUM / ALUMINIUM
BLANCO WHITE / BLANC

ACABADOS PATAS / LEG FINISH / FINITION DES JAMBES

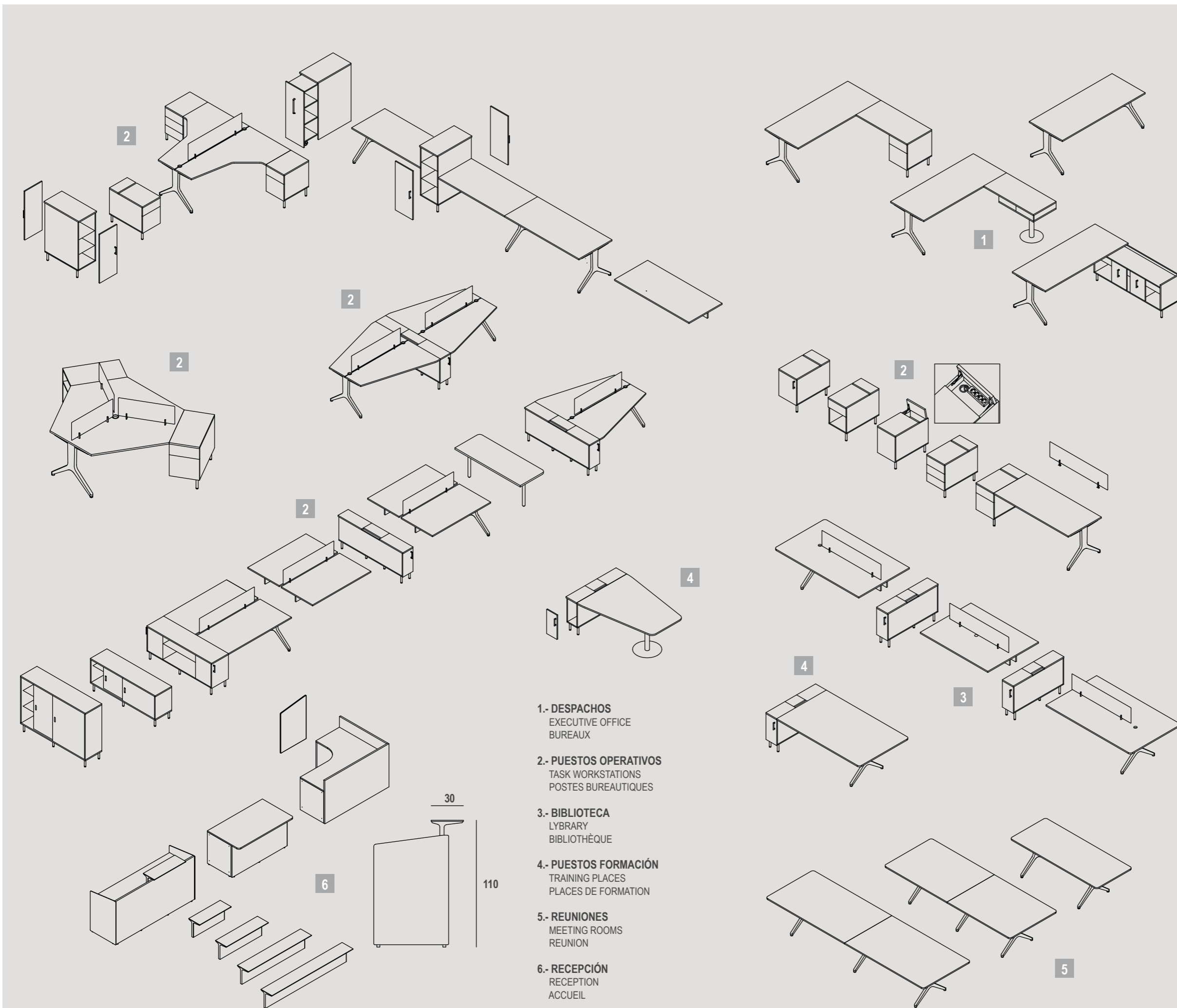

- 1.- **DESPACHOS**
EXECUTIVE OFFICE
BUREAUX
- 2.- **PUESTOS OPERATIVOS**
TASK WORKSTATIONS
POSTES BUREAUTIQUES
- 3.- **BIBLIOTECA**
LYBRARY
BIBLIOTHÈQUE
- 4.- **PUESTOS FORMACIÓN**
TRAINING PLACES
PLACES DE FORMATION
- 5.- **REUNIONES**
MEETING ROOMS
REUNION
- 6.- **RECEPCIÓN**
RECEPTION
ACCUEIL

30

110

teSEO

EQUIPAMIENTO INTEGRAL DE OFICINA

Designed by
ISMOBEL



DIRECCIÓN

MANAGEMENT / DIRECTION 02>03



TESEO
EQUIPAMIENTO
INTEGRAL
DE OFICINA



DIRECCIÓN

MANAGEMENT / DIRECTION

EQUIPAMIENTO INTEGRAL DE OFICINA

Planificar y ser eficaces en todo tipo de proyectos, es importante para que todos los elementos se ajusten a las necesidades de cada una de las diferentes particularidades.

DELFO cuenta con la versatilidad que viene a solucionar estas necesidades.



EQUIPMENT OFFICE INTEGRAL

Planning and being effective in all types of projects, it is important for all elements to meet the needs of each of the different features.

DELFO has the versatility that comes to solve these needs.

EQUIPEMENT BUREAU INTÉGRAL

Planification et efficacité dans tous les types de projets, il est important que tous les éléments répondent aux besoins de chacune des différentes fonctionnalités.

DELFO a la polyvalence nécessaire pour répondre à ces besoins.



Instalación

INSTALLATION / INSTALLATION

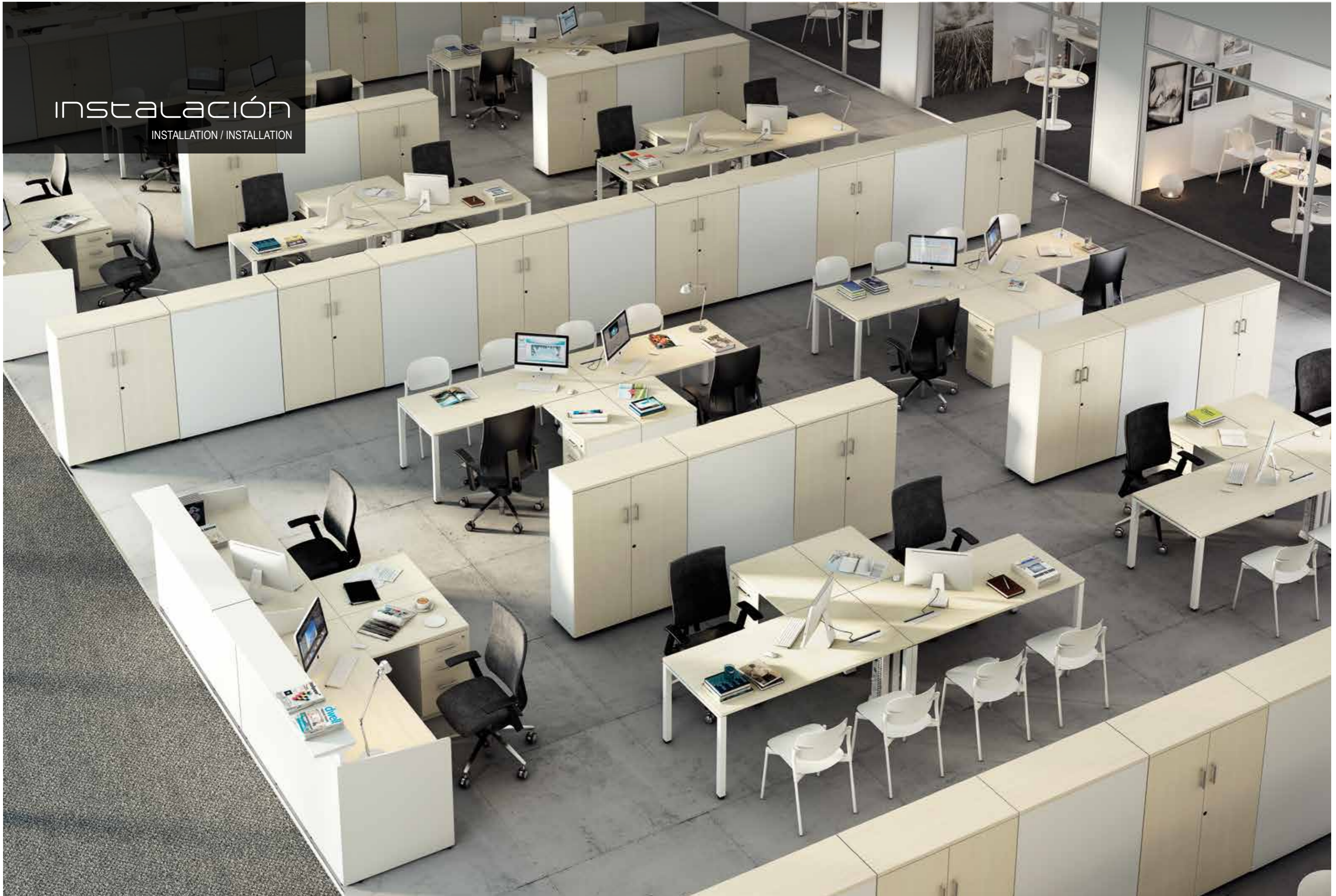

reunión
OPERATIVE / OPÉRATIVE



OPERATIVO

OPERATIVE / OPÉRATIVE



OPERATIVO

OPERATIVE / OPÉRATIVE



OPERATIVO

OPERATIVE / OPÉRATIVE



NEGRO BLACK / NOIR
GRAFITO GRAPHITE/ANTHRACITE
GRIS GREY / GRIS
ALUMINIO ALUMINIUM/ALUMINIUM
BLANCO WHITE / BLANC



ARCE MAPLE / ERABLE
BACO BACO / BACO
HAYA BEECH / HÊTRE
ROBLE OAK / POIRIER
CEREZO CHERRY / MÉRISIE

ELEMENTOS VERTICALES
 VERTICAL ELEMENTS / ÉLÉMENTS VERTICAUX



AZUL BLUE / BLEU
NUDE NUDE / NUDE
VERDE GREEN / VERT
AMARILLO YELLOW / JAUNE
TERRACOTA TERRACOTTA / TERRE CUITE

acabados

FINISHINGS / FINITIONS

Los colores de este catálogo son orientativos, la percepción de los mismos puede variar respecto al original.

The colours of this catalogue are reference, the perception of the same can vary with respect to the original one.

Les couleurs figurant sur le catalogue sont indicatifs, ils peuvent varier para rapport à l'original.

ACABADOS METÁLICOS
 METAL FINISHING / METAL FINITIONS



NEGRO (*) BLACK / NOIR
ALUMINIO ALUMINIUM / ALUMINIUM
BLANCO WHITE / BLANC

(*)
 NO STANDAR / Consulter
 NON-STANDARD / Consult
 NON STANDARD / Consulter

DELFOS

EQUIPAMIENTO INTEGRAL DE OFICINA





OPERATIVE / OPÉRATIVE
Operativo



MANAGEMENT / DIRECTION
DIRECCIÓN



TRAINING / FORMATION
Formación





BENCH / BENCH
BENCH



NEGRO / BLACK / NOIR
GRAFITO / GRAPHITE / ANTHRACITE
GRIS / GREY / GRIS
ALUMINIO / ALUMINIUM / ALUMINIUM
BLANCO / WHITE / BLANC



ARCE / MAPLE / ERABLE
BACO / BACO / BACO
HAYA / BEECH / HÊTRE
ROBLE / OAK / POIRIER
CEREZO / CHERRY / MÉRISIE

ELEMENTOS VERTICALES
VERTICAL ELEMENTS / ÉLÉMENTS VERTICAUX



AZUL / BLUE / BLEU
NUDE / NUDE / NUDE
VERDE / GREEN / VERT
AMARILLO / YELLOW / JAUNE
TERRACOTA / TERRACOTTA / TERRE CUITE

acabados
FINISHINGS / FINITIONS

Los colores de este catálogo son orientativos, la percepción de los mismos puede variar respecto al original.

The colours of this catalogue are reference, the perception of the same can vary with respect to the original one.

Les couleurs figurant sur le catalogue sont indicatifs, ils peuvent varier para rapport à l'original.

ACABADOS METÁLICOS
METAL FINISHING / METAL FINITIONS



NEGRO (*) / BLACK / NOIR
ALUMINIO (*) / ALUMINIUM / ALUMINIUM
BLANCO / WHITE / BLANC

(*) NO STANDAR / Consultar
NON-STANDARD / Consult
NON STANDARD / Consulter

eco

EQUIPAMIENTO INTEGRAL DE OFICINA

Designed by
ISMOBEL

IS
ISMOBEL

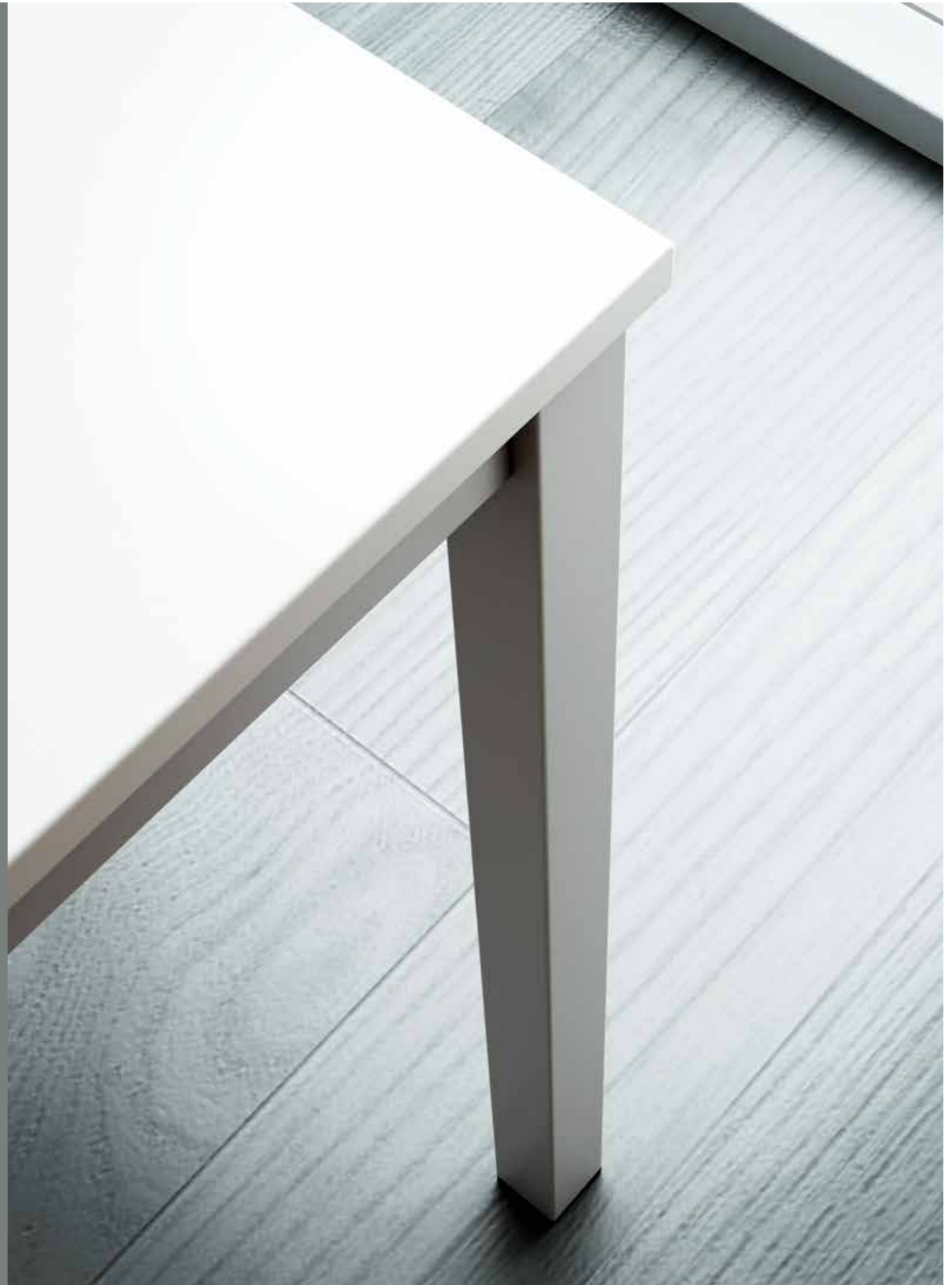



MEETING / RÉUNION
reunión



POLYVALENT / POLYVALENTE
MULTIUSOS



MANAGEMENT / DIRECTION
DIRECCIÓN



TRAINNIG / FORMATION
Formación











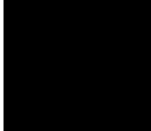
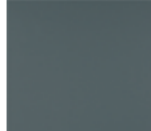
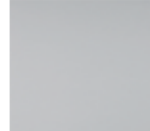

acabados

FINISHINGS / FINITIONS

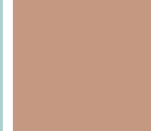
Los colores de este catálogo son orientativos, la percepción de los mismos puede variar respecto al original.

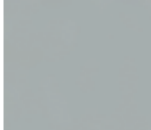
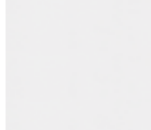
The colours of this catalogue are reference, the perception of the same can vary with respect to the original one.

Les couleurs figurant sur le catalogue sont indicatifs, ils peuvent varier para rapport à l'original.

								
NEGRO BLACK NOIR	GRAFITO GRAPHITE ANTHRACITE	GRIS GREY GRIS	ARCE MAPLE ERABLE	BACO BACO BACO	HAYA BEECH HÊTRE	AZUL BLEU BLEU	NUUDE NUUDE NUUDE	VERDE GREEN VERT
								
ALUMINIO ALUMINIUM ALUMINIUM	BLANCO WHITE BLANC	ROBLE OAK POIRIER	CEREZO CHERRY MÉRISIE	AMARILLO YELLOW JAUNE	TERRACOTA TERRACOTTA TERRE CUITE			

ACABADOS METÁLICOS

METAL FINISHING / METAL FINITIONS

		
NEGRO (*) BLACK / NOIR	ALUMINIO ALUMINIUM / ALUMINIUM	BLANCO WHITE / BLANC

(*) NO STANDAR / Consulter
NON-STANDARD / Consult
NON STANDARD / Consulter

CERES

EQUIPAMIENTO INTEGRAL DE OFICINA

Designed by
Sigfrido Bilbao

IS
ISMOBEL





UN DISEÑO ARMÓNICO
 EN SUS FORMAS Y RACIONAL EN SU
 IMPLANTACIÓN, ORIENTADO A LOS EN-
 TORNOS DONDE PRIMA LA PRODUCTI-
 VIDAD, LA EFECTIVIDAD DEL ESPACIO
 DE TRABAJO Y LA ERGONOMÍA.

Design by: SIGFRIDO BILBAO

*Un dessin harmonique dans les formes et ra-
 tionnel dans s'implantation. C'est adressé au
 environnement où est prioritaire la producti-
 vité, l'efficacité du espace et l'ergonomie.*

DIRECCIÓN



OPERATIVO





CERES

UN DISEÑO CREADO Y DESARROLLADO EN EL AÑO 2003
PARA PERPETUARSE EN EL TIEMPO.

*CERES
a design created and developed
in 2003 to perpetuate in time.*

*CERES
c'est un dessin fait et développé
dans l'année 2003 pour se perpétuer
dans le temp.*





**ATEMPORAL
Y DE TENDENCIA**
ASÍ SON LOS RASGOS PRINCIPALES
QUE DEFINEN ESTA SERIE

*Timeless and trendy, the main features
that define this series are.*

*C'est un dessin intemporel et avec ten-
dance. De sorte qu'ils sont les caracté-
ristiques principaux de cette série.*



CERES,
MANTENIENDO SU ESENCIA, ACTUALIZA Y
AMPLÍA SU GAMA PARA ADAPTARSE A LAS
NUEVAS ESTRUCTURAS DE TRABAJO.

*CERES,
with its own essence, updated and expands its
range to adapt itself to new ways of working.*

*CERES,
toujours avec s'essence, actualisé et aussi il
agrandi la gamme de produits, pour s'adapter au
les nouvelles structures de travail.*



REUNIÓN







ALMACENAJE



ACABADOS FINISHES / FINITIONS

Los colores de este catálogo son orientativos, la percepción de los mismos puede variar respecto al original.

The colours of this catalogue are reference, the perception of the same can vary with respect to the original one.

Les couleurs figurant sur le catalogue sont indicatifs, ils peuvent varier para rapport à l'original.

ELEMENTOS VERTICALES VERTICAL ELEMENTS / ÉLÉMENTS VERTICAUX



NEGRO
BLACK
NOIR

AZUL
BLUE
BLEU

NUDE
NUDE
NUDE



VERDE
GREEN
VERT

AMARILLO
YELLOW
JAUNE

TERRACOTA
TERRACOTTA
TERRE CUITE

ACABADOS GENERALES GENERAL FINISHES / FINITIONS GÉNÉRALES



NEGRO
BLACK
NOIR

GRAFITO
GRAPHITE
ANTHRACITE

GRIS
GREY
GRIS

ALUMINIO
ALUMINIUM
ALUMINIUM

BLANCO
WHITE
BLANC



BACO
BACO
BACO

HAYA
BEECH
HÊTRE

ROBLE
OAK
POIRIER

CEREZO
CHERRY
MÉRISIE

SKY

MOBILITY SYSTEMS

Designed by
ISMOBEL



SKY

Sentirse cómodo en cada situación es importante para desempeñar una tarea diferente en cada momento.



Feeling comfortable in each situation is important to perform a different task in each moment.

Se sentir confortable dans chaque situation est important pour accomplir une tâche différente à chaque moment.

SKY
MOBILITY SYSTEMS



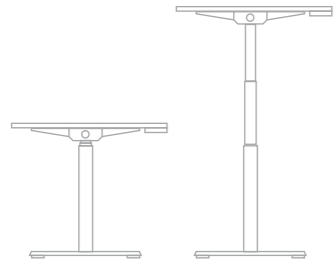

OPERATIVO

OPERATIVE / OPÉRATIVE

UP... DOWN

En un mismo espacio, en diferentes momentos, SKY se adapta a tí.
¿QUÉ NECESITAS?



*In the same space, at different times,
SKY adapts to you.*

WHAT DO YOU NEED?

*Dans le même espace, à des moments
différents, SKY s'adapte à vous.*















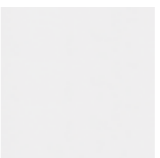

DE QUOI AVEZ-VOUS BESOIN?



SKY

ACABADOS / FINISHINGS / FINITIONS

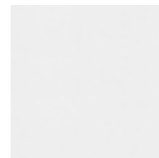

					MELAMINAS MELAMINE MÉLAMINES
NEGRO BLACK / NOIR	GRAFITO GRAPHITE / ANTHRACITE	GRIS GREY / GRIS	ALUMINIO ALUMINIUM / ALUMINIUM	BLANCO WHITE / BLANC	
					
ARCE MAPLE / ERABLE	BACO BACO / BACO	HAYA BEECH / HÊTRE	ROBLE OAK / POIRIER	CEREZO CHERRY / MÉRISIE	
					ELEMENTOS VERTICALES VERTICAL ELEMENTS ÉLÉMENTS VERTICAUX
AZUL BLEU / BLEU	NUDE NUDE / NUDE	VERDE GREEN / VERT	AMARILLO YELLOW / JAUNE	TERRACOTA TERRACOTTA / TERRE CUITE	
			(*) NO STANDARD / Consulter NON-STANDARD / Consulter NON STANDARD / Consulter		ACABADOS METÁLICOS METAL FINISHING METAL FINITIONS
NEGRO (*) BLACK / NOIR	ALUMINIO ALUMINIUM / ALUMINIUM	BLANCO WHITE / BLANC			

Los colores de este catálogo son orientativos, la percepción de los mismos puede variar respecto al original.

The colours of this catalogue are reference, the perception of the same can vary with respect to the original one.

Les couleurs figurant sur le catalogue sont indicatifs ils peuvent varier para rapport à l'original.

FEDra

MOBILITY SYSTEMS

Designed by
ISMOBEL



FEDra

La versatilidad y funcionalidad de esta serie como factor diferenciador en entornos cambiantes.



The versatility and functionality of this series as a differentiating factor in changing environments.

La polyvalence et la fonctionnalité de cette série comme facteur différentiel dans des environnements changeants.

REUNIÓN

MEETING / RÉUNION



Cada ocasión precisa de una necesidad, una manera diferente de abordar el problema, por eso FEDRA es una herramienta que permite solucionar cualquier necesidad,
FÁCIL, RÁPIDO Y VERSÁTIL.

RE/CONFIGURA



Each occasion requires a must, a different way to solve the problem, so FEDRA is a tool that can solve any need.

EASY, FAST AND VERSATILE.

Chaque occasion a besoin d'une nécessité, une manière différente d'aborder le problème, c'est pourquoi FEDRA est un outil qui permet de répondre à n'importe quel besoin.

FACIL, RAPIDE ET POLYVALENT.



Una formación clásica con un elemento contemporáneo, una solución inmediata a un momento concreto.

A classic training with a contemporary element, an immediate solution to a specific moment.

Une formation classique avec un élément contemporain, une solution immédiate à un moment spécifique.

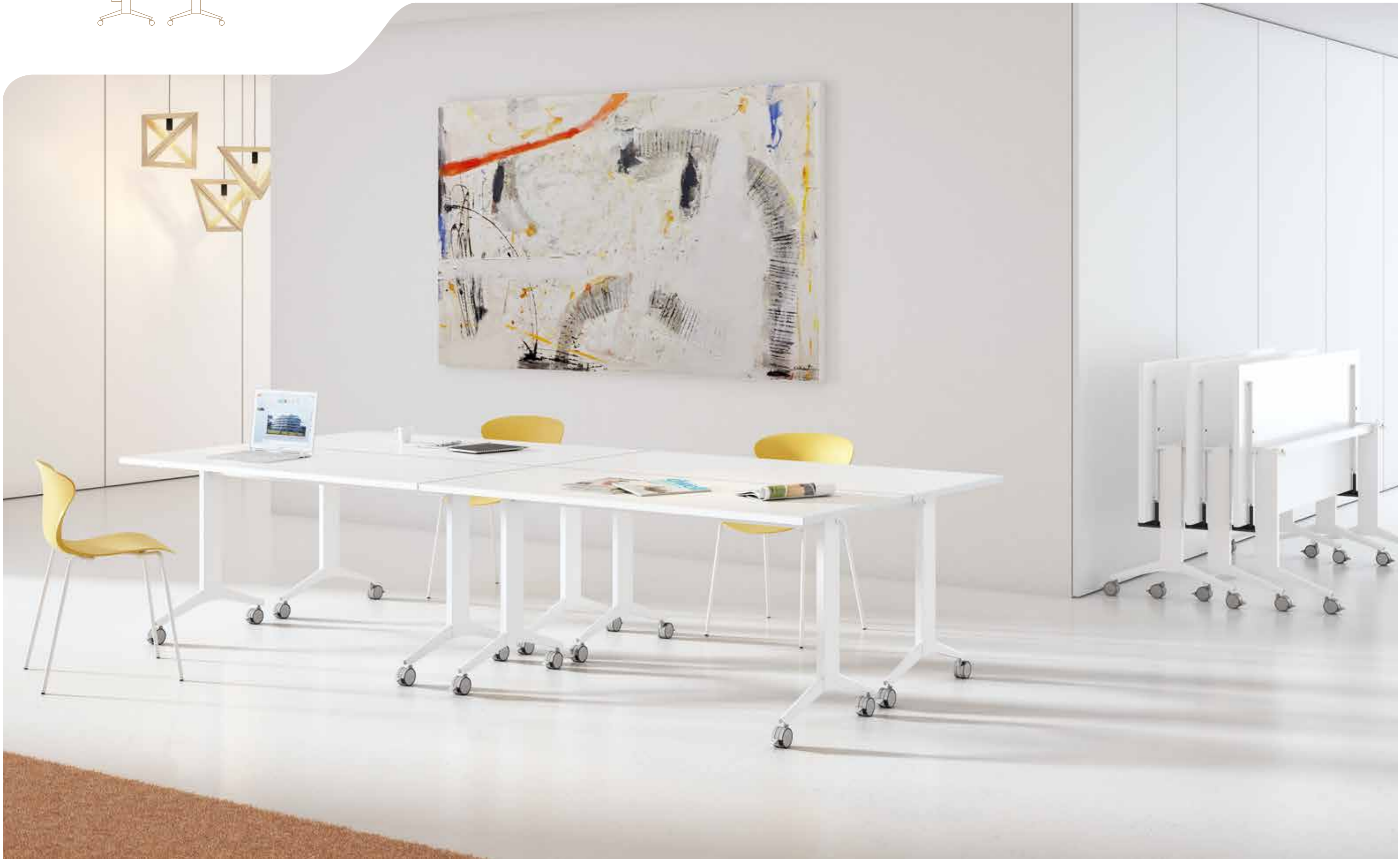
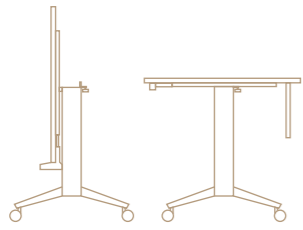



FEDRA

ACABADOS / FINISHINGS / FINITIONS



NEGRO BLACK / NOIR
GRAFITO GRAPHITE / ANTHRACITE
GRIS GREY / GRIS
ALUMINIO ALUMINIUM / ALUMINIUM
BLANCO WHITE / BLANC



ARCE MAPLE / ERABLE
BACO BEECH / HÊTRE
HAYA BEECH / HÊTRE
ROBLE OAK / POIRIER
CEREZO CHERRY / MÉRISIE



AZUL BLEU / BLEU
NUDE NUDE / NUDE
VERDE GREEN / VERT
AMARILLO YELLOW / JAUNE
TERRACOTA TERRACOTTA / TERRE CUIE



NEGRO (*) BLACK / NOIR
ALUMINIO ALUMINIUM / ALUMINIUM
BLANCO WHITE / BLANC

(*) NO STANDAR / Consulrar
 NON-STANDARD / Consult
 NON STANDARD / Consulter

MELAMINAS MELAMINE MÉLAMINES

ELEMENTOS VERTICALES VERTICAL ELEMENTS ÉLÉMENTS VERTICAUX

ACABADOS METÁLICOS METAL FINISHING METAL FINITIONS

Los colores de este catálogo son orientativos, la percepción de los mismos puede variar respecto al original.

The colours of this catalogue are reference, the perception of the same can vary with respect to the original one.

Les couleurs figurant sur le catalogue sont indicatifs ils peuvent varier para rapport à l'original.



DIRECCIÓN

EXECUTIVE / DIRECTION

176 zen

192 nereeo 2

204 nereeo 3



zen

MOBILIARIO DE DIRECCIÓN

Designed by
SIGFRIDO BILBAO

IS
ISMOBEL



Mesa sobre armarios con rinconera. Roble / Blanco.
Silla modelo Oxford.
Confidente modelo Níger.



ZEN

Mobiliario de Dirección

La palabra ZEN es la abreviación de Zenna que es la pronunciación en japonés de la palabra china chánna, que a su vez deriva de la palabra sánscrita dhiana, que significa "meditación". El zen busca la experiencia de la sabiduría más allá del discurso racional.

Desde esta filosofía y concepto, **Ismobel** ha desarrollado una renovada línea de Mobiliario de Dirección, ZEN.

La importancia de tomar decisiones, bien meditadas.

The word ZEN is the abbreviation of Zenna which is the pronunciation in Japanese of the Chinese word chánna, which also derives from the Sanskrit word dhiana, which means "meditation". The Zen seeks the experience of wisdom beyond rational discourse.

From this philosophy and concept, **Ismobel** has developed a renewed line of Management Furniture, ZEN.

The importance of making decisions, well thought out.

Le mot zen est l'abrégement de zenna qui est la prononciation un japonais du mot chinois chánna qui dérive à son tour du mot Sanscrit Dhiana qui signifie "méditation". Le Zen cherche l'expérience de la sagesse plus loin du discours rationnel.

Depuis cette philosophie et concept, **Ismobel** a développé une ligne renouvelée et rénovée de mobilier de direction, Zen.

L'importance de prendre des décisions, bien médités.

*Mesa sobre armarios. Blanco.
Silla modelo Siena.
Confidente modelo Riga.*



Mesa sobre armarios de diferente altura. Blanco / Roble.
Silla modelo Bonn.
Confidente modelo Níger.
Sofá modelo Glasgow.



*Mesa con ala y cajonera. Ceniza / Inoxidable.
Armarios con casillero grande. Ceniza / Blanco.
Silla modelo Bonn.*



*Mesa reunión. Ceniza / Inoxidable.
Silla modelo Sevilla.*



Mesa sobre armarios. Blanco / Negro.
Silla modelo Siena.
Confidente modelo Riga.





DETALLES

Details / Des Détails

La serie ZEN se caracteriza por el acabado en todos sus detalles. Una ejecución muy cuidada que transmite carácter a esta serie.

The ZEN series is characterized by the finish in all its details. A very careful execution that transmits character to this series.

La série ZEN est caractérisée par achevé dans tous ses détails. Une exécution très soignée qui transmet un caractère à cette série.



nerEO 2

MOBILIARIO DE DIRECCIÓN

Designed by
SIGFRIDO BILBAO



DIRECCIÓN

Reception / Réception





REUNIÓN

Meeting / Réunion

CLÁSICO
Classic / Classique







CONTEMPORÁNEO
Contemporary / Contemporain

nerEO 3

MOBILIARIO DE DIRECCIÓN

Designed by
SIGFRIDO BILBAO

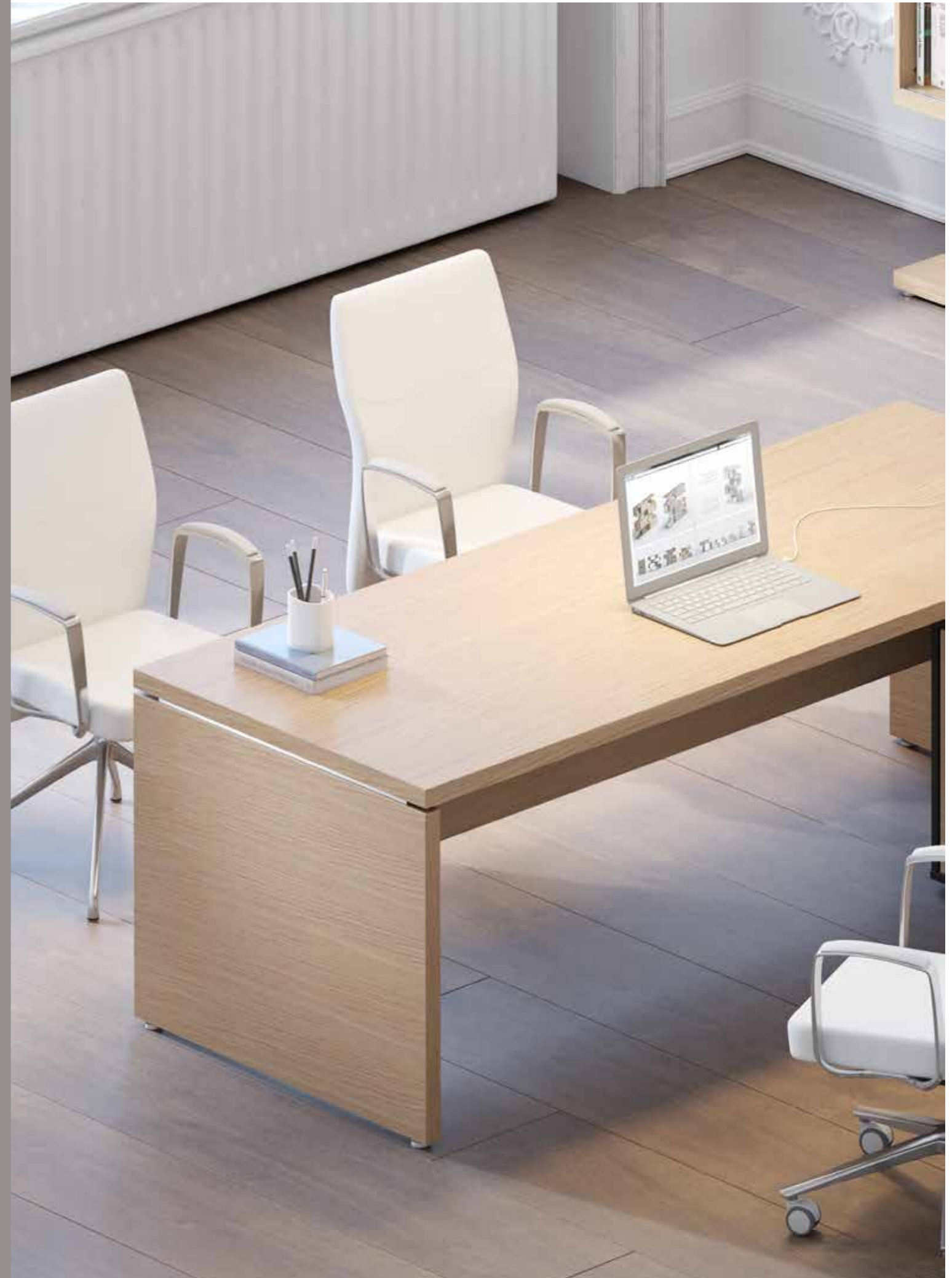



Management

Elegant and functional, straight lines that outline seriousness and integration with the environment. NEREO 3 adapts to the most demanding needs in each of its functions.

Direction

Lignes droites élégantes et fonctionnelles qui soulignent le sérieux et l'intégration avec l'environnement. NEREO 3 s'adapte aux besoins les plus exigeants dans chacune de ses fonctions.

Dirección

Elegante y funcional, líneas rectas que perfilan seriedad e integración con el entorno. NEREO 3 se adapta a las más exigentes necesidades en cada una de sus funciones.



Diversidad

Un mismo espacio con diferentes necesidades en puestos de trabajo. Una convivencia de las diferentes soluciones que aporta equilibrio a la composición de espacios multidisciplinarios.

Diversity

The same space with different needs in jobs. A coexistence of the different solutions that brings balance to the composition of multidisciplinary spaces.

Diversité

Le même espace avec des besoins différents dans les emplois. Une coexistence des différentes solutions qui équilibre la composition des espaces pluridisciplinaires.



Configuración

Ante una misma necesidad, NEREO 3 aporta diferentes soluciones y configuraciones pensadas para cada usuario.



Setting

Faced with the same need, NEREO 3 provides different solutions and configurations designed for each user.

Paramètre

Face au même besoin, NEREO 3 propose différentes solutions et configurations conçues pour chaque utilisateur.





Meeting

Big decisions require spaces according to needs at the height of the circumstances. Large tables, elegant and functional.

Réunion

Les grandes décisions nécessitent des espaces en fonction des besoins à la hauteur des circonstances. Grandes tables, élégantes et fonctionnelles.

Reunión

Grandes decisiones requieren espacios acorde a necesidades a la altura de las circunstancias. Grandes mesas, elegantes y funcionales.

Versatilidad

La versatilidad de la serie NEREO 3 permite encontrar la solución a la necesidad de cada puesto de trabajo, de su configuración, para que estas cumplan los objetivos marcados.



Versatility

The versatility of the NEREO 3 series allows finding the solution to the needs of each job, its configuration so that they meet the objectives set.

Polyvalence

La polyvalence de la série NEREO 3 permet de trouver la solution aux besoins de chaque travail, sa configuration afin qu'ils répondent aux objectifs fixés.





Personalidad de líneas puras

Sin perder de vista la funcionalidad, no podemos olvidarnos del diseño, el ADN de Ismobel, piezas creadas para dar carácter a los espacios, para vestirlos y para brillar con luz propia.



Clean lined perso-nality

Without losing sight of functionality, we cannot forget about design, Ismobel's DNA, pieces created to give spaces character, to dress them up and to shine with their own light.

Personnalité épu-rée

Sans perdre de vue la fonctionnalité, nous ne pouvons pas oublier le design, l'ADN d'Ismobel, des pièces créées pour donner du caractère aux espaces, les habiller et les faire briller de leur propre lumière.



Arquitectura funcional

Geometrías que resuelven las funcionalidades que necesitas, objetos, libros, tus cosas de cada día que acaban encontrando su sitio, su espacio.

Functional architecture

Geometries that solve the functionalities you need, objects, books, your everyday things that end up finding their place, their space.

Architecture fonctionnelle

Des géométries qui résolvent les fonctionnalités dont vous avez besoin, des objets, des livres, vos objets du quotidien qui finissent par trouver leur place, leur espace.





Coffee Tables

No todo es trabajar, una pausa, un momento de descanso o de encuentro, NEREO 3 se adapta al concepto Contract con estas piezas que abre las puertas a espacios destinados al hogar, hotel...

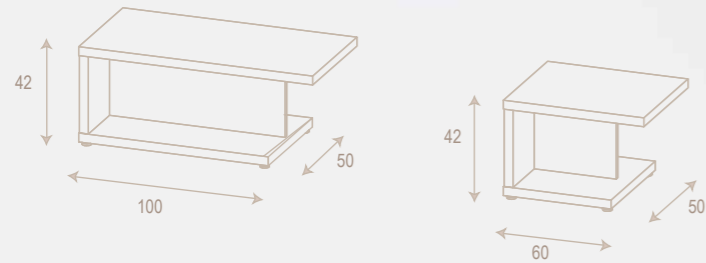

Not everything is work, a break, a moment of rest or meeting, NEREO 3 adapts to the Contract concept with these pieces that open the doors to spaces for the home, hotel...

Tout n'est pas travail, pau-se, moment de repos ou de rencontre, NEREO 3 s'adapte au concept Contract avec ces pièces qui ouvrent les portes d'espaces pour la maison, l'hôtel...

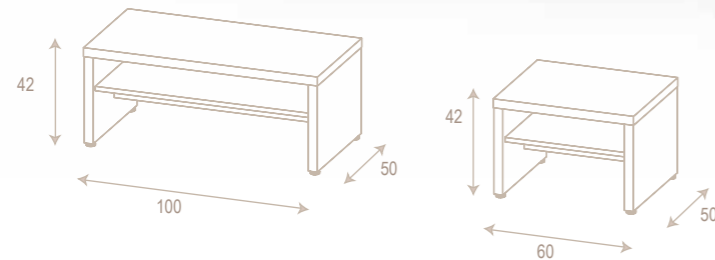

Acabados

Los colores de este catálogo son orientativos, la percepción de los mismos puede variar respecto al original.

The colours of this catalogue are reference, the perception of the same can vary with respect to the original one.

Les couleurs figurant sur le catalogue sont indicatifs, ils peuvent varier para rapport à l'original.

Finishings / Finitions

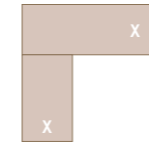

ENCIMERAS Y COSTADOS

Countertops and Sides
Comptoirs et côtés

X = 40mm



BLANCO
WHITE / BLANC

ROBLE
OAK / POIRIER

BACO
BACO / BACO



ACABADOS VERTICALES

Vertical Finishes
Finitions verticales

X = 19mm



NEGRO
BLACK / NOIR

GRAFITO
GRAPHITE / ANTHRACITE

GRIS
GREY / GRIS

ALUMINIO
ALUMINIUM / ALUMINIUM

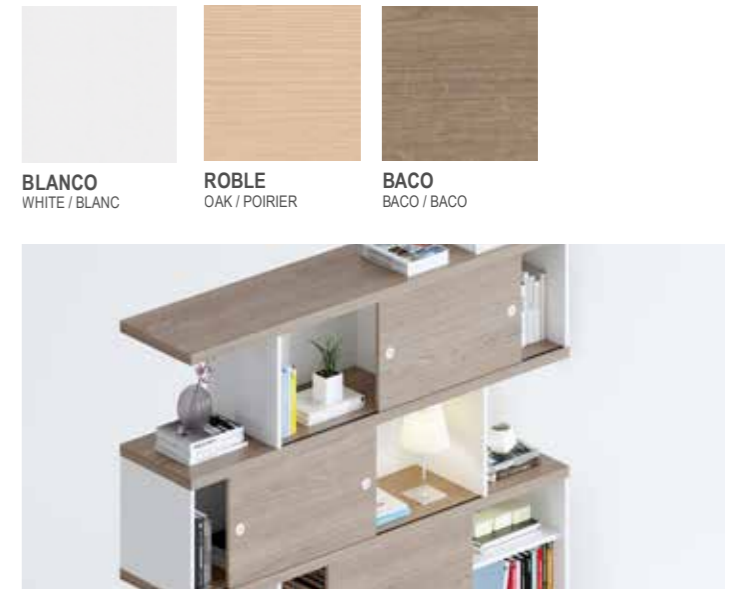

Estanterías

Shelves / Des Étagères

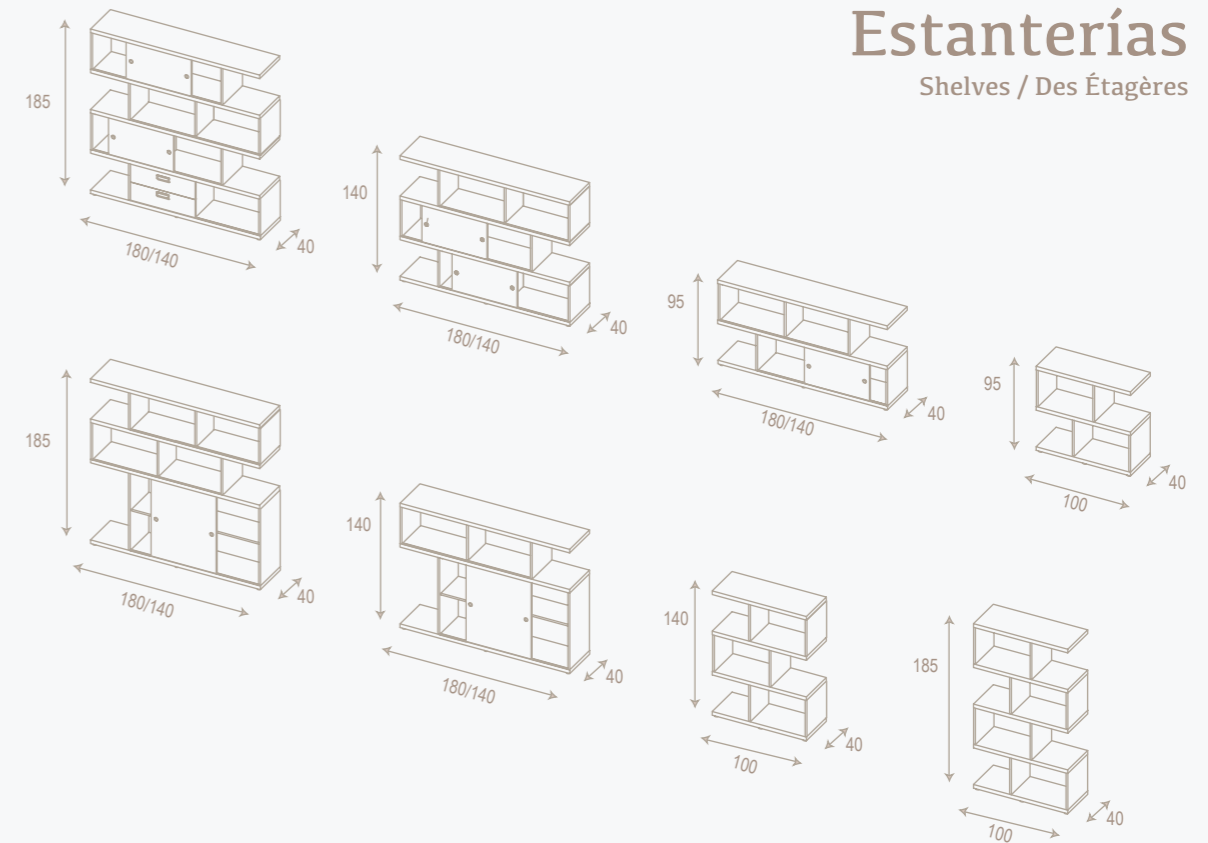



BIBLIOTECAS Y DIVISORIAS

LIBRARIES AND DIVIDERS / BIBLIOTHÈQUES ET SÉPARATEURS

226 BIBLOS

246 horus

270 Panel



ISMOBEL

BIBLOS

BIBLIOTECAS

Designed by
SIGFRIDO BILBAO





Cada ambiente es diferente, el uso, el espacio, la percepción. BIBLOS dispone de una gama de materiales que le permite adaptarse a esos espacios y transmitir las sensaciones en lugares de estudio, formación, en definitiva en lugares de inspiración y concentración..

Cerezo, roble, haya... como texturas de la naturaleza nos acerca a ella, nos transmite su calidez y autenticidad.















SEÑALIZACIÓN Y APOYALIBROS
Signaling and bookholder / Signaletique et serres-livres



NIVELADOR DE ESTANTERÍA
Shelf leveller / Vérin de réglage niveau



RUEDAS CARRO
Trolley's rollers / Roulettes chariot



LÁMPARA
Lamp / Éclairage



SOPORTE CPU
CPU holder / Support UC



AMARRE A PARED
Wall fixer / Crochet mural



DOBLE ESTANTE
Double shlef / Double tablette



ESTANTE INCLINADO REVISTERO
Magazine shelf / Tablette présentoir inclinée



DOBLE ESTANTE CD Y LIBROS PEQUEÑOS
Double shlef for CD and small books
Double Tablette gradin

ACABADOS TAPA LATERAL / Side panel finishes / Finitions panneaux latéraux



CEREZO
Cherry / Mèrisier



ROBLE
Oak / Poirier



HAYA
Beech / Hêtre



BACO
Baco / Baco



ARCE
Maple / Erable



METACRILATO
Metacrylate / Métacrylate



NEGRO
Black / Noir



GRAFITO
Graphite / Anthracite



GRIS
Grey / Gris



BLANCO
White / Blanc



ALUMINIO
Aluminium / Aluminium

ACABADOS METÁLICOS / Metal Finishing / Metal Finitions



NEGRO (*)
BLACK / NOIR



ALUMINIO
ALUMINIUM / ALUMINIUM

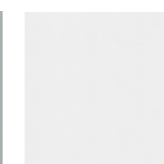

BLANCO
WHITE / BLANC

(*) NO STANDAR / Consulter
NON-STANDARD / Consult
NON STANDARD / Consulter



CARRO INFORMÁTICO RUEDAS
Computer trolley / Chariot informatique



ESTANTERÍA FIJA
Fixed shelf / Étagère fixe



UNIÓN ESTANTERÍAS
Shelves joining / Union d'assemblage de modules



PERCHERO
Rack / Porte chapeaux

LATERALES
Sides / Latéraux

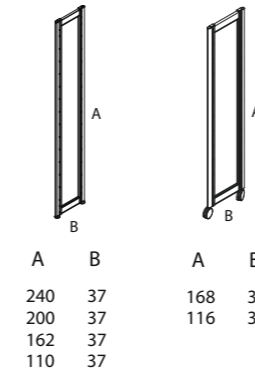

ESTANTES
Shelves / Tablettes

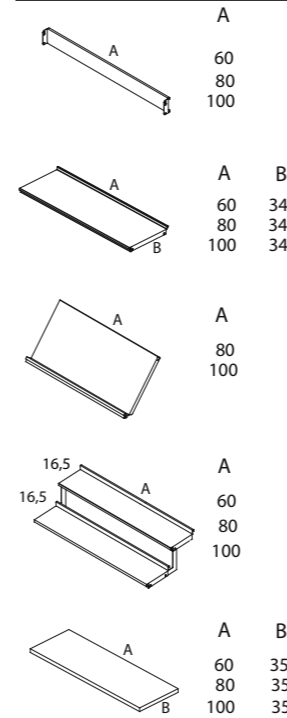

ACCESORIOS
Accessories / Accessoires

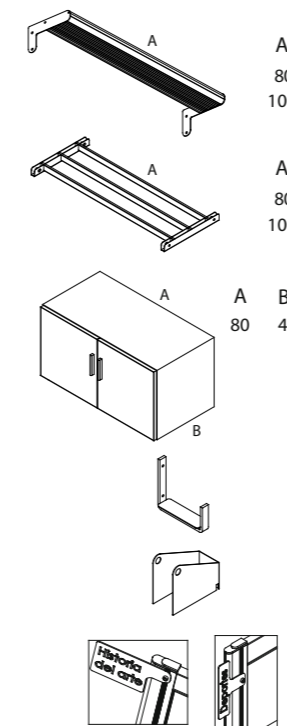

MESAS
Desks / Bureaux

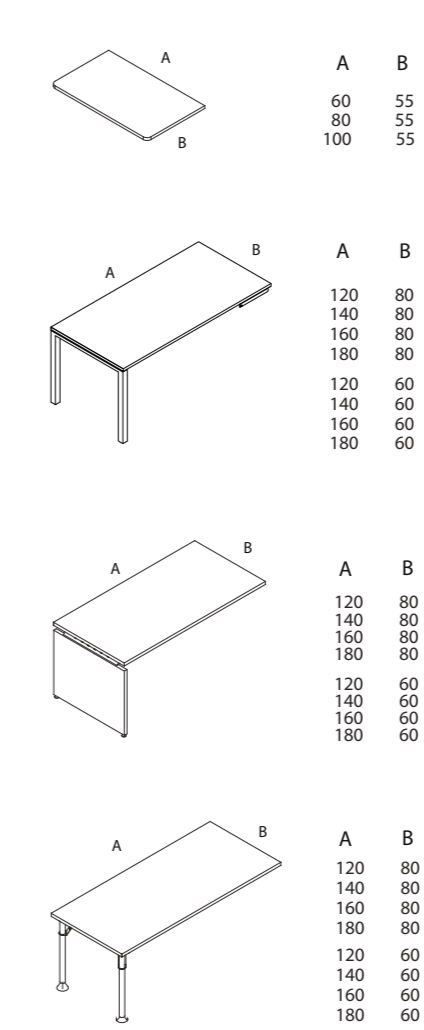

MESAS FO
L-shaped desks / Bureaux compacts

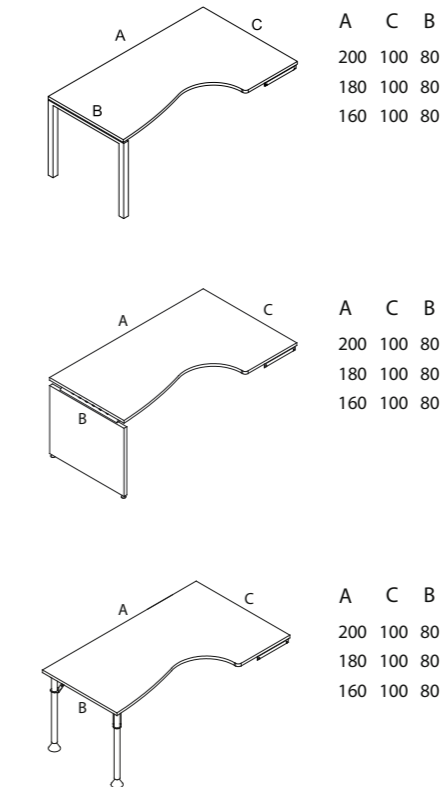

EJEMPLOS DE MONTAJE
Assembling samples / Exemples d'assemblage

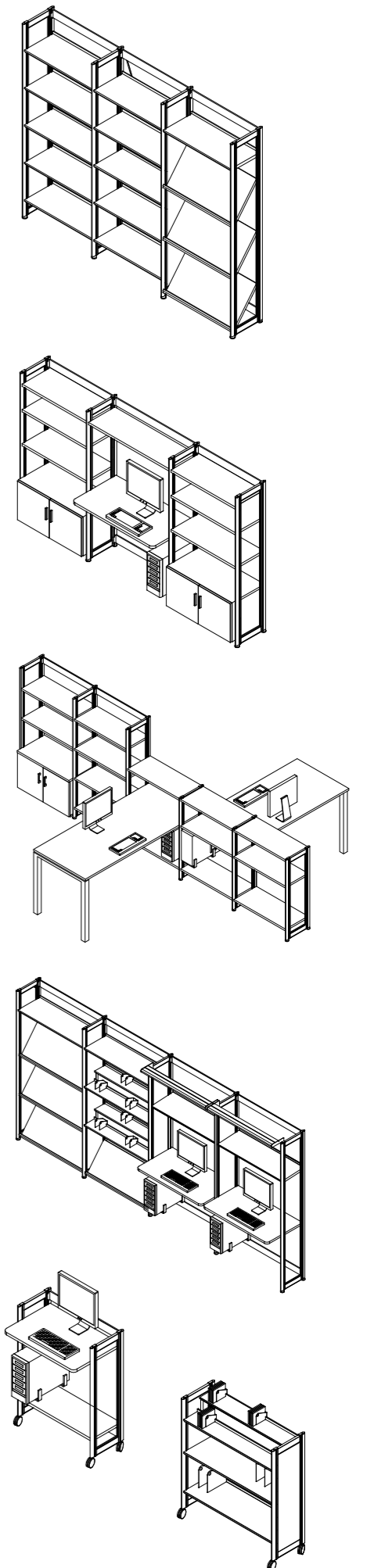

horus

BIOMBOS

Designed by
SIGFRIDO BILBAO





HORUS

BIOMBOS

Design by: SIGFRIDO BILBAO

HORUS / BIOMBOS
UNA SOLUCIÓN VERSÁTIL Y PRÁCTICA PARA DIVIDIR UN ESPACIO Y CREAR ÁREAS INDEPENDIENTES DENTRO DE UN MISMO ENTORNO.

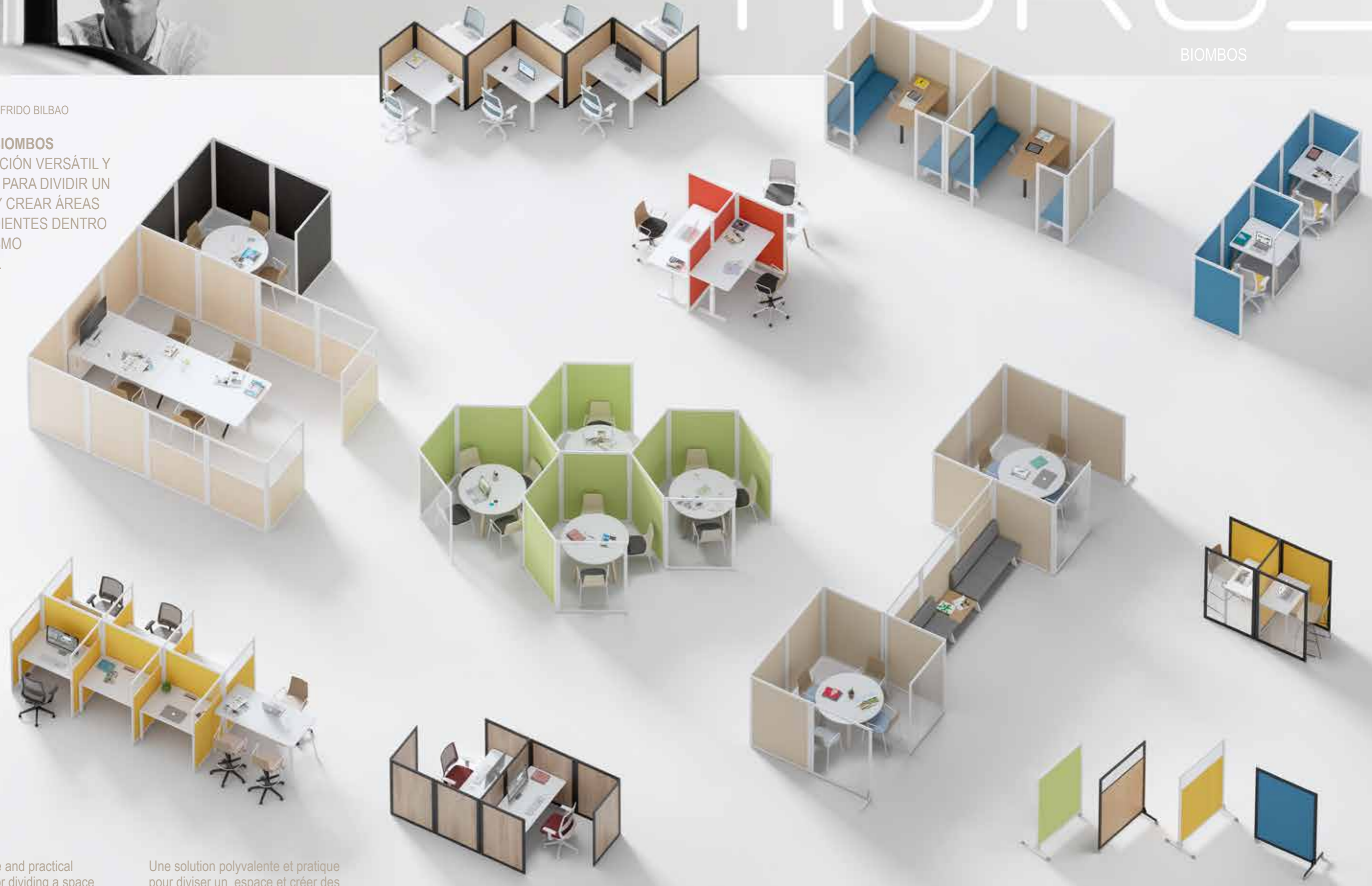

A versatile and practical solution for dividing a space and creating independent areas within the same around.

Une solution polyvalente et pratique pour diviser un espace et créer des zones indépendantes dans le même autour.

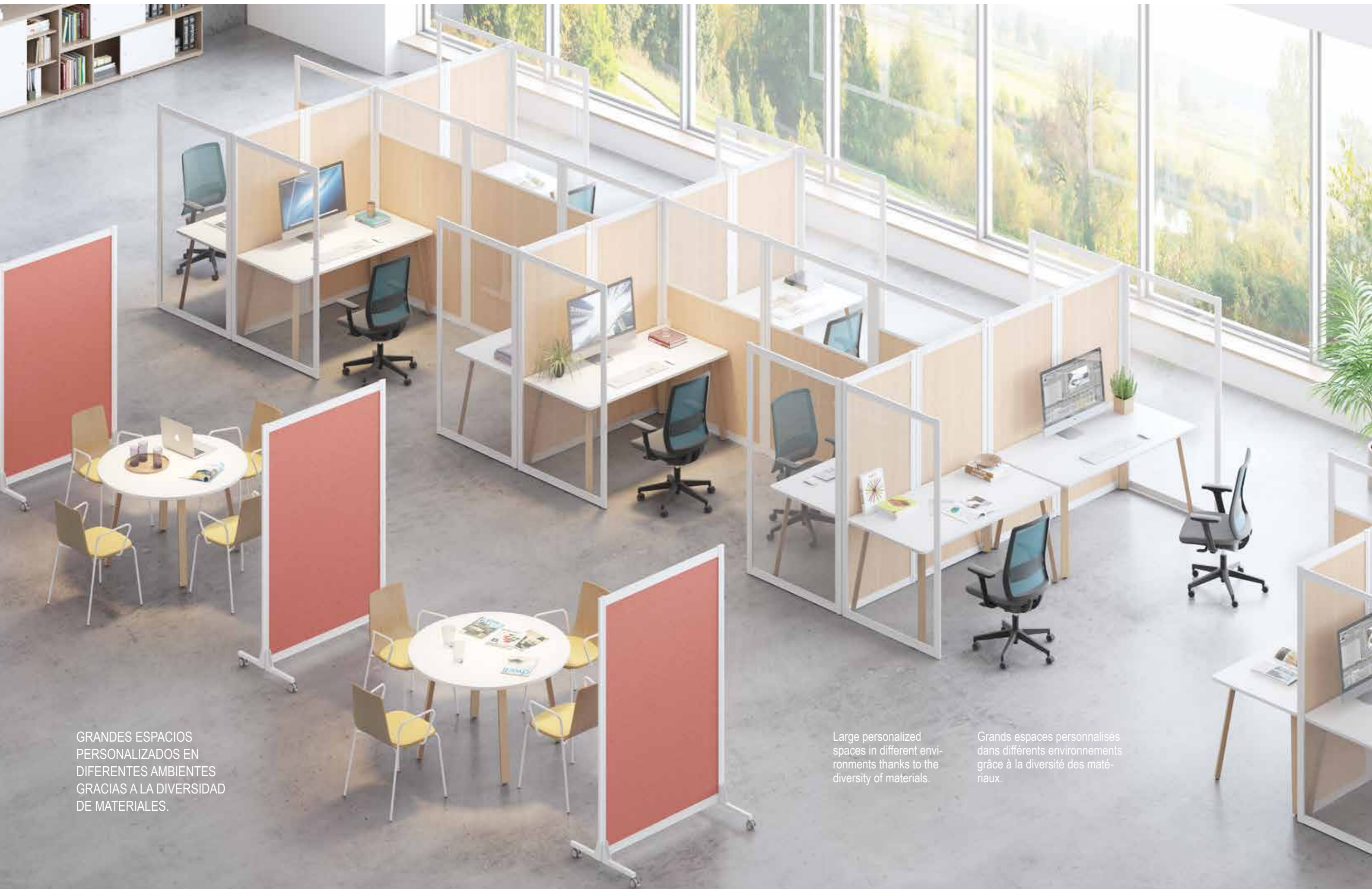

GRANDES ESPACIOS
PERSONALIZADOS EN
DIFERENTES AMBIENTES
GRACIAS A LA DIVERSIDAD
DE MATERIALES.

Large personalized
spaces in different envi-
ronments thanks to the
diversity of materials.

Grands espaces personnalisés
dans différents environnements
grâce à la diversité des maté-
riaux.





Closeness and discretion,
two concepts that live in
harmony.

Proximité et discrétion,
deux concepts qui
vivent en harmonie.



CERCANIA Y DISCRECIÓN,
DOS CONCEPTOS QUE
CONVIVEN EN ARMONÍA.





SIN MOLESTAR,
TOMARSE UN DESCANSO SE
COMPAGINA CON EL TRABAJO
DEL RESTO DEL EQUIPO.
LA ACÚSTICA COMO UN
VALOR INDISPENSABLE.



Dont disturb, taking a break is
combined with the work of the
rest of the team. Acoustics as
an essential value.

Ne pas deranger, prendre une pau-
se est combiné au travail du reste
de l'équipe. L'acoustique comme
valeur essentielle.







A GUSTO DEL CONSUMIDOR.
 ES UNA REALIDAD LA DIVERSIDAD
 DE TIPOS DE ESPACIOS Y DEL
 TAMAÑO DE ESTOS, **HORUS** SE
 ADAPTA A LAS NECESIDADES
 DEL TRABAJO Y SOBRE TODO
 DEL ESPACIO.

To like the consumer.
 The diversity of types of spaces
 and their sizes is a reality, **HORUS**
 adapts to the needs of the work and
 above all of the space.

Aimer le consommateur.
 La diversité des types d'espaces
 et de leurs tailles est une réalité,
HORUS s'adapte aux besoins du
 travail et surtout de l'espace.



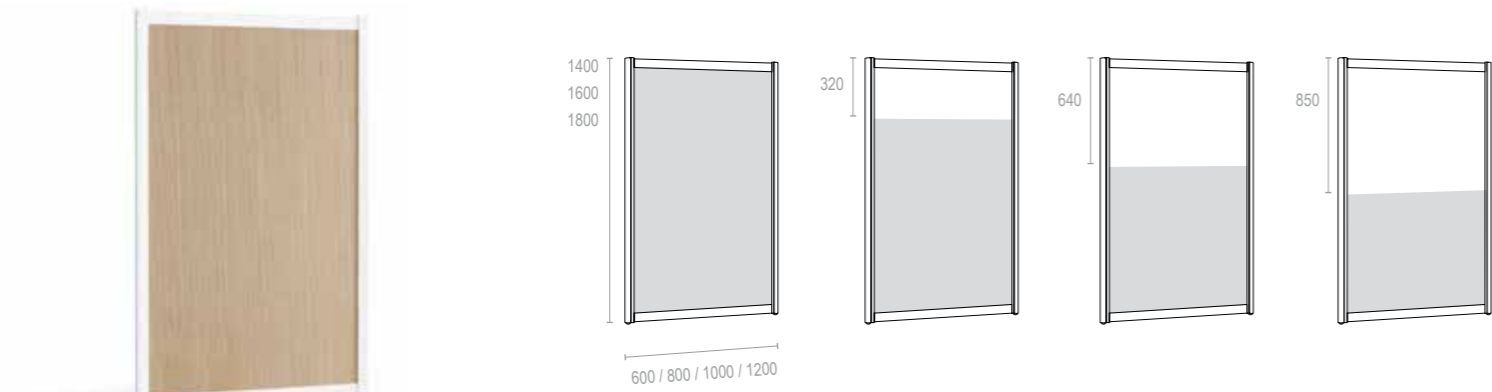

MELAMINA
MELAMINE
MÉLAMINA



TAPIZADO SOBRE PET (Acústico)
UPHOLSTERED ON PET (Acoustic)
REMOURRÉ SUR PET (Acoustique)

TAPIZADO SOBRE MELAMINA
UPHOLSTERED ON MELAMINE
REMOURRÉ SUR MÉLAMINE

MIXTO TAPIZADO SOBRE MELAMINA /
METACRILATO
MIXED UPHOLSTERED ON MELAMINE /
METHACRYLATE
REMOURRAGE MIXTE SUR MÉLAMINE /
MÉTHACRYLATE

MIXTO TAPIZADO SOBRE MELAMINA /
METACRILATO
MIXED UPHOLSTERED ON MELAMINE /
METHACRYLATE
REMOURRAGE MIXTE SUR
MÉLAMINE / MÉTHACRYLATE



MELAMINA / METACRILATO
MELAMINE / METHACRYLATE
MÉLAMINE / MÉTHACRYLATE

MELAMINA / METACRILATO
MELAMINE / METHACRYLATE
MÉLAMINE / MÉTHACRYLATE

MELAMINA / MELAMINA
MELAMINE / MELAMINE
MÉLAMINE / MÉLAMINE

MELAMINA / MELAMINA
MELAMINE / MELAMINE
MÉLAMINE / MÉLAMINE



MIXTO TAPIZADO SOBRE
MELAMINA / MELAMINA
MIXED UPHOLSTERED ON
MELAMINE / MELAMINE
REMOURRAGE MIXTE SUR
MELAMINE / MÉLAMINE

MIXTO TAPIZADO SOBRE
MELAMINA / MELAMINA
MIXED UPHOLSTERED ON
MELAMINE / MELAMINE
REMOURRAGE MIXTE SUR
MELAMINE / MÉLAMINE

MIXTO MELAMINA / TAPIZADO
SOBRE MELAMINA
MIXED MELAMINE / UPHOLSTERED
ON MELAMINE
MÉLANGE MIXTE / REMOURRÉ
SUR MÉLAMINE

MIXTO MELAMINA / TAPIZADO
SOBRE MELAMINA
MIXED MELAMINE / UPHOLSTERED
ON MELAMINE
MÉLANGE MIXTE / REMOURRÉ
SUR MÉLAMINE



METACRILATO
METHACRYLATE
MÉTHACRYLATE

PIZARRA MAGNÉTICA (1 o 2 caras)
MAGNETIC BOARD (1 or 2 sides)
TABLEAU MAGNÉTIQUE (1 ou 2 faces)



MELAMINA / PIZARRA MAGNÉTICA (1 o 2 caras)
MELAMINA / MAGNETIC BOARD (1 or 2 sides)
MÉLAMINA / TABLEAU MAGNÉTIQUE (1 ou 2 faces)



MIXTO TAPIZADO
MIXED UPHOLSTERED
REMOURRAGE MIXTE

MIXTO TAPIZADO
MIXED UPHOLSTERED
REMOURRAGE MIXTE



MIXTO TAPIZADO MELAMINA /
PIZARRA MAGNÉTICA (1 o 2 caras)
MIXED MELAMINE /
MAGNETIC BOARD (1 or 2 sides)
MÉLANGE MIXTE/
TABLEAU MAGNÉTIQUE (1 ou 2 faces)

UNIONES

CONNECTIONS / CONNEXIONS



UNIÓN LINEA / 180°
LINE CONNECTION 180°
CONNEXION LIGNE 180°



UNIÓN 90° (2 VÍAS)
CONNECTION 90° (2 WAY)
CONNEXION 90° (2 VOIES)



UNIÓN 90° (3 VÍAS)
CONNECTION 90° (3 WAY)
CONNEXION 90° (3 VOIES)



UNIÓN 90° (4 VÍAS)
CONNECTION 90° (4 WAY)
CONNEXION 90° (4 VOIES)



UNIÓN 120° (2 VÍAS)
CONNECTION 120° (2 WAY)
CONNEXION 120° (2 VOIES)



UNIÓN 120° (3 VÍAS)
CONNECTION 120° (3 WAY)
CONNEXION 120° (3 VOIES)

COMPLEMENTOS

ACCESSORIES / ACCESSOIRES



PATA DOBLE
DOUBLE LEG
PIED DOUBLE



PATA DOBLE RUEDAS
DOUBLE LEG WITH CASTORS
PIED DOUBLE AVEC ROUES



COLGADOR
HANGER
CINTRE



PATA INDIVIDUAL
SINGLE LEG
JAMBE UNIQUE



PATA DOBLE CON RUEDAS + RUEDA
DOUBLE LEG WITH CASTORS + CASTOR
DOUBLE PIED AVEC ROUES + ROUE



BANDEJA
TRAY
PLATEAU

ACABADOS

FINISHINGS / FINITIONS

MELAMINAS

MELAMINE / MÉLAMINES

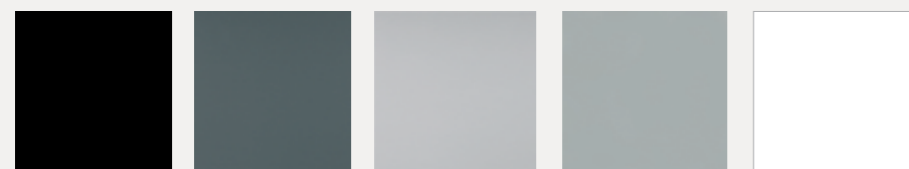

NEGRO
BLACK
NOIR

GRAFITO
GRAPHITE
ANTHRACITE

GRIS
GREY
GRIS

ALUMINIO
ALUMINIUM
ALUMINIUM

BLANCO
WHITE
BLANC

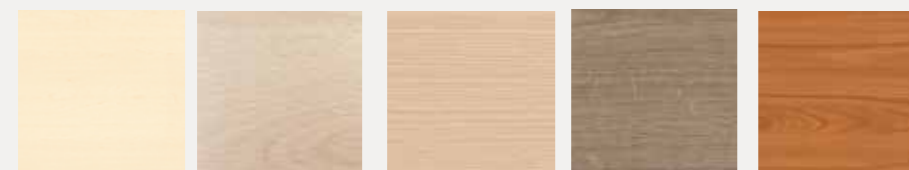

ARCE
MAPLE
ERABLE

HAYA
BEECH
HÊTRE

ROBLE
OAK
POIRIER

BACO
BACO
BACO

CEREZO
CHERRY
MÉRISIE

METÁLICOS

METAL PARTS / MÉTALLIQUES

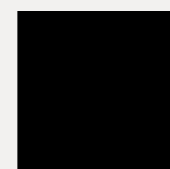

NEGRO
BLACK
NOIR

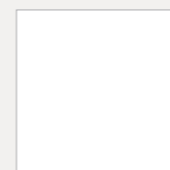

BLANCO
WHITE
BLANC

TAPICERÍAS / BASIC F.R.

UPHOLSTERY / TAPISSERIES



106

088

755

462

098

077



055

084

170

315

108

009

METACRILATO TRASPARENTE

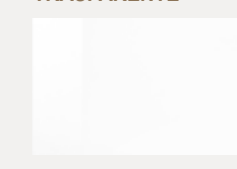

TRANSPARENT METHACRYLATE
METHACRYLATE TRANSPARENT

PIZARRA MAGNÉTICA BRILLO

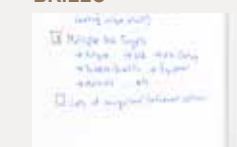

GLOSS MAGNETIC WHITEBOARD
TABLEAU BLANC MAGNÉTIQUE
BRILLANT

PANEL

DIVISORIAS

Designed by
SIGFRIDO BILBAO

IS
ISMOBEL





ATENCIÓN Y PROTECCIÓN

Mantener el contacto visual pero con el menor contacto directo posible con el público, con nuestro cliente, con nuestros compañeros sin perder el estilo y el diseño.
Composiciones personalizables y perfectamente integradas en el entorno. Elementos separadores que se anclan perfectamente a los diferentes modelos de mesas.



Maintain eye contact and maintain distances with the public, with our client, with our colleagues without losing style and design. Customizable compositions and perfectly integrated into the environment. Screens that are perfectly anchored to the different models of tables

Maintenez un contact visuel et maintenez des distances avec le public, avec notre client, avec nos collègues sans perdre de style et de design. Compositions personnalisables et parfaitement intégrées à l'environnement. Des éléments de séparation parfaitement ancrés aux différents modèles de tables.

Hay momentos que la privacidad es determinante. Estas a su vez tienen su particularidad en su funcionalidad. Cada una de ellas necesita una solución personalizada y PANEL resuelve esta necesidad. Altos, bajos, individuales, colectivos...



There are times when privacy is decisive. These in turn have their particularity in their functionality. Each of them needs a personalized solution and PANEL solves this need. High, low, individual, collective ...

Il y a des moments où la vie privée est décisive. Ceux-ci ont à leur tour leur particularité dans leur fonctionnalité. Chacun d'eux a besoin d'une solution personnalisée et PANEL répond à ce besoin. Haut, bas, individuel, collectif ...





ACABADOS FINISHINGS / FINITIONS



METACRILATOS
METHACRYLATE
MÉTACRYLATE

TRASPARENTE
TRANSPARENT / TRANSPARENT



NEGRO
BLACK / NOIR



GRAFITO
GRAPHITE / ANTHRACITE



GRIS
GREY / GRIS



ALUMINIO
ALUMINIUM / ALUMINIUM

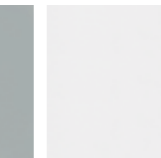

BLANCO
WHITE / BLANC

MELAMINAS
MELAMINE
MÉLAMINES



ARCE
MAPLE / ERABLE



BACO
BACO / BACO



HAYA
BEECH / HÊTRE



ROBLE
OAK / POIRIER



CEREZO
CHERRY / MÉRISIE



AZUL
BLEU / BLEU



NUDE
NUDE / NUDE



VERDE
GREEN / VERT



AMARILLO
YELLOW / JAUNE



TERRACOTA
TERRACOTTA / TERRE CUITE

ELEMENTOS VERTICALES
VERTICAL ELEMENTS
ÉLÉMENTS VERTICAUX

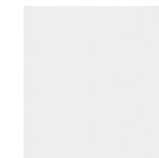

BLANCO
WHITE / BLANC

ACABADOS METÁLICOS
METAL FINISHING
METAL FINITIONS

Los colores de este catálogo son orientativos, la percepción de los mismos puede variar respecto al original.

The colours of this catalogue are reference, the perception of the same can vary with respect to the original one.

Les couleurs figurant sur le catalogue sont indicatifs ils peuvent varier para rapport à l'original.



almacenaje

STORAGE / STOCKAGE



almacenaje





ORDEN, ORGANIZACIÓN,
DISCRECIÓN, DIVERSIDAD.

Las necesidades particulares de cada usuario, de cada momento, requiere soluciones que se adapten a cada una de ellas, pero teniendo en cuenta la privacidad, la conectividad y la integración en cada una de las instalaciones.

ORDEN, ORGANIZACIÓN,
DISCRECIÓN, DIVERSIDAD.

Las necesidades particulares de cada usuario, de cada momento, requiere soluciones que se adapten a cada una de ellas, pero teniendo en cuenta la privacidad, la conectividad y la integración en cada una de las instalaciones.



ORDEN, ORGANIZACIÓN,
DISCRECIÓN, DIVERSIDAD.

Las necesidades particulares de cada usuario, de cada momento, requiere soluciones que se adapten a cada una de ellas, pero teniendo en cuenta la privacidad, la conectividad y la integración en cada una de las instalaciones.





ACABADOS FINISHES / FINITIONS

Los colores de este catálogo son orientativos, la percepción de los mismos puede variar respecto al original.

The colours of this catalogue are reference, the perception of the same can vary with respect to the original one.

Les couleurs figurant sur le catalogue sont indicatifs, ils peuvent varier para rapport à l'original.

ELEMENTOS VERTICALES VERTICAL ELEMENTS / ÉLÉMENTS VERTICAUX



AZUL
BLE
BLEU

NUDE
NUDE
NUDE

VERDE
GREEN
VERT



AMARILLO
YELLOW
JAUNE

TERRACOTA
TERRACOTTA
TERRE CUITE

ACABADOS GENERALES GENERAL FINISHES / FINITIONS GÉNÉRALES



NEGRO
BLACK
NOIR

GRAFITO
GRAPHITE
ANTHRACITE

GRIS
GREY
GRIS

ALUMINIO
ALUMINIUM
ALUMINIUM

BLANCO
WHITE
BLANC



ARCDE
MAPLE
ERABLE

BACO
BACO
BACO

HAYA
BEECH
HÊTRE

ROBLE
OAK
POIRIER

CEREZO
CHERRY
MÉRISIE



SIGFRIDO BILBAO

LA IMPORTANCIA DE LA EXPERIENCIA DE USUARIO.

Para ISMOBEL, el diseño ha sido la columna vertebral de todo el desarrollo de producto, un diseño basada en la experiencia de usuario, en la experiencia de años en el sector y en la capacidad de evolucionar el producto final para la satisfacción del usuario. Los medios técnicos y humanos son fundamentales para llegar a ese objetivo.

Es por eso que tanto el DEPARTAMENTO DE DISEÑO como la colaboración con diseñadores de dilatada experiencia como SIGFRIDO BILBAO, nos permite ofrecer un catálogo completo de soluciones para las diferentes necesidades del mercado.



DEPARTAMENTO DISEÑO ISMOBEL

Para ISMOBEL, el diseño ha sido la columna vertebral de todo el desarrollo de producto, un diseño basada en la experiencia de usuario, en la experiencia de años en el sector y en la capacidad de evolucionar el producto final para la satisfacción del usuario.

Los medios técnicos y humanos son fundamentales para llegar a ese objetivo.

Es por eso que tanto el DEPARTAMENTO DE DISEÑO como la colaboración con diseñadores de dilatada experiencia como SIGFRIDO BILBAO, nos permite ofrecer un catálogo completo de soluciones para las diferentes necesidades del mercado.

Para ISMOBEL, el diseño ha sido la columna vertebral de todo el desarrollo de producto, un diseño basada en la experiencia de usuario, en la experiencia de años en el sector y en la capacidad de evolucionar el producto final para la satisfacción del usuario.

Los medios técnicos y humanos son fundamentales para llegar a ese objetivo.

Es por eso que tanto el DEPARTAMENTO DE DISEÑO como la colaboración con diseñadores de dilatada experiencia como SIGFRIDO BILBAO, nos permite ofrecer un catálogo completo de soluciones para las diferentes necesidades del mercado.

THE SOLU- TION



Grupo Imobel

ESTAMOS PREPARADOS
WE ARE READY / NOUS SOMMES PRÊTS

AIDIMME 
INSTITUTO TECNOLÓGICO
METALMECÁNICO, MUEBLE, MADERA, EMBALAJE Y AFINES



ECODISEÑO ISO 14006:2011

THE SOLUTION



Grupo Ismobel

Polígono La Portalada II
C/ Cordonera 5
26006 LOGROÑO (La Rioja)
T. +34 941 230 752 / F. +34 941 248 977
ismobel@ismobel.com

ismobel.com



THE COLLEC- TION

CATÁLOGO
GENERAL
SILLERÍA

Vers. 6.0

JDM
seating

Grupo Smobel

**THE
COLLEC-
TION**

CATÁLOGO
GENERAL
SILLERÍA

Vers. 6.0

*Somos muchos
y muy diferentes,
pero nuestra
singularidad
es la diversidad.*

Una diversidad de países, culturas, costumbres,
personas, que están obligadas a coexistir.

Dentro de las empresas existen diferentes, áreas, perfiles,
equipos, proyectos y objetivos.
Cada uno con sus necesidades concretas.

*Te proponemos un
viaje por la diversidad
por un mundo
de posibilidades.*

WE ARE MANY AND SO DIFFERENT,
BUT DIVERSITY IS OUR UNIQUENESS.

A diversity of countries, cultures, customs, people,
that are forced to coexist.

In the companies there are different areas, profiles,
teams, projects and objectives. Each one with their
specific needs.

WE PROPOSE A TRIP THROUGH DIVERSITY.
IN A WORLD OF POSSIBILITIES.

NOUS SOMMES BEAUCOUP ET TRÈS DIFFÉRENTS MAIS
NOTRE SINGULARITÉ EST LA DIVERSITÉ.

Une diversité de pays, de cultures, de coutumes,
de personnes qui sont obligées à coexister.

À l'intérieur des entreprises ils existent différents, des áreas,
des profils, des équipes, des projets et des objectifs. Chacun
avec ses nécessités concrètes.

NOUS TE PROPOSONS UN VOYAGE PAR LA DIVERSITÉ.
PAR UN MONDE DE POSSIBILITÉS.

Más de 35 años aportando soluciones integrales a un sector en constante evolución.

JDM cuenta con una infraestructura de 25.000m² situada estratégicamente con grandes ventajas logísticas y equipada con la tecnología necesaria para cada producto.

Un equipo de más de 100 personas, hace que JDM sea una empresa consolidada que aporta valor y conocimiento.



Nuestra singularidad, nuestra capacidad de diversificación.

More than 35 years giving completed solutions to a sector in continuous evolution. Jdm seating has a 25,000m² infrastructure located strategically with great logistics benefits and equipped with the necessary technology for each product.

A team of more than 100 people, makes jdm seating a consolidated company that provides value and knowledge.

Our uniqueness, our capacity for diversification.

Plus de 35 ans en donnant des solutions intégrales à un secteur dans une évolution continue. Jdm seating dispose d'une infrastructure de 25.000 M² située stratégiquement avec des grands avantages logistiques et équipée de la technologie nécessaire pour chaque produit.

Une équipe de plus de 100 personnes fait que jdm seating soit une entreprise consolidée qui apporte une valeur et une connaissance.

Notre singularité, notre capacité de diversification.

Entendemos esta diversidad y trabajamos para dar respuesta a nuevas necesidades.

We understand this diversity and we work to give answers to new needs.

Nous entendons cette diversité et travaillons pour donner la réponse à des nouvelles nécessités.

JDM
seating

40 2021
1981
Grupo Asmabel



ECODISEÑO ISO 14006:2011

Entendemos un mundo mejor, más sostenible, más justo,

y es por ello que desde hace tiempo apostamos por tomar medidas que minimicen nuestro impacto sobre el medio ambiente, y toda nuestra superficie que consta de **25.000 m² está cubierta de placas solares.**

and that is why for some time we have been committed to taking measures that minimize our impact on the environment, and our entire surface, which consists of 25.000 m², is covered with solar panels.

et c'est pourquoi depuis un certain temps, nous nous sommes engagés à prendre des mesures qui minimisent notre impact sur l'environnement, et toute notre surface, qui se compose de 25.000 m², est couverte de panneaux solaires.

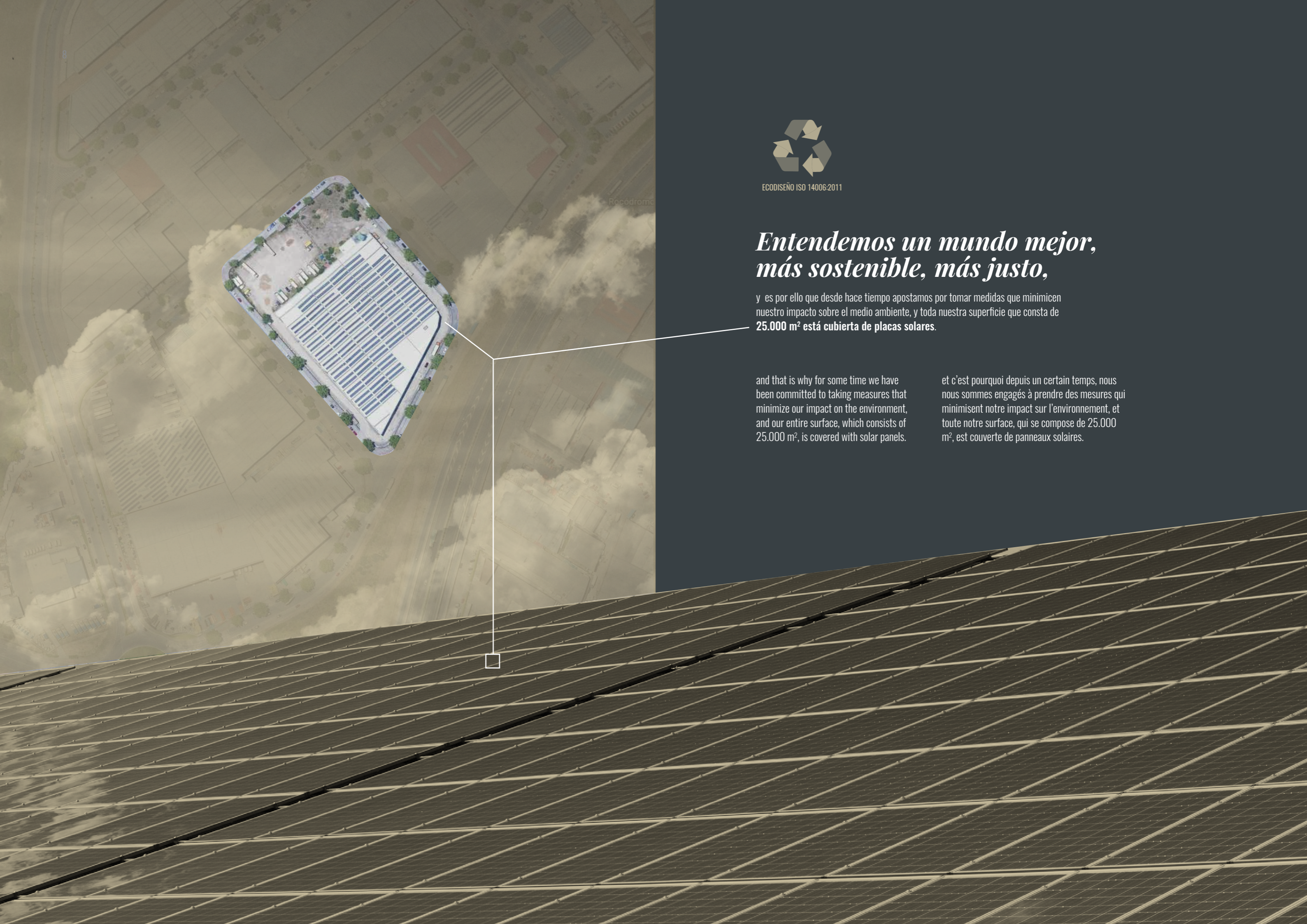

THE COLLECTION

JDM SEATING, presenta el resultado de un trabajo en equipo, donde el equipo de producción junto con diseñadores de prestigio, hemos detectado las necesidades concretas del mercado y que nos da como resultado, The Collection.

The Collection presenta la gama de productos de JDM SEATING para Dirección, Operativa, Colectividades y Contract.

JDM SEATING, presents the result of a teamwork, where the production team together with prestigious designers have detected the specific needs of the market and that gives us as a result, The Collection.

The Collection presents the range of JDM SEATING products for Management, Task, Community and Contract chairs.

JDM SEATING presente le résultat d'un travail en équipe, où l'équipe de production avec dessinateurs de prestige ont détecté les nécessités concrètes du marché et qui nous donne comme résultat The Collection.

The Collection présente la gamme de produits de JDM SEATING pour Direction, Opérationnelle, Des Collectivités et Contract.

DIRECCIÓN

Executive / Direction



BONN 16



BELICE 22



TRENTO 28



ZURICH 34



OXFORD 40



SIENA 46



BARI 52

OPERATIVA

Operative / Operative



BREMEN 60



CÓRCEGA 66



NICEA 72



PARMA 78



ROMA 84



BERNA 90



PALMA 94



AZORES 100



ODESA 106



ATENAS 112



SOFÍA 118

COLECTIVIDADES

Community Chairs / Collectivités



YALTA 124



SEVILLA 146



CRETA 152



VIENA 158



MANILA 166



FRESNO 172



IOWA 180



CHIPRE 186



FLORIDA 192



VERONA 198



BAHIA 204

CONTRACT & SOFT SEATING

Contract & Soft Seating / Contract & Soft Seating



BASEL 210



GLASGOW 218



TRIPOLI 224



DAKAR 230



NIGER 236



SEVILLA 242



VENEZIA 248



MALTA 254



LORCA 258



ALBERTA 262



MEMPHIS 268



ANGOLA 274



VANCOUVER 278

BANCADAS

Bench / Banque



284

ACABADOS

Finishes Finit



294

DISEÑADORES

Designers / Concepteurs



306



**GESTIÓN ES HACER
LAS COSAS BIEN,
LIDERAZGO ES HACER
LO CORRECTO.**

PETER DRUCKER.

“Consultor y profesor de negocios, tratadista austriaco, y abogado de carrera, considerado el mayor filósofo de la administración del siglo XX”

“MANAGEMENT IS DOING THINGS
RIGHT, LEADERSHIP IS DOING THE
RIGHT THINGS.”

Peter Drucker

“Consultant and business professor, Aus-
trian treatisee, and lawyer, considered the
greatest philosopher of the 20th century
administration .”

“UNE GESTIÓN EST DE FAIRE LES CHO-
SES BIEN. UN LEADER SHIP EST DE FAIRE
LE CORRECT.”

Peter Drucker

“Conseiller et professeur d'affaires, un
autrichien auteur de traités et l'avocat de
carrière.Considéré le plus grand philosophe
de l'administration du siècle XX.”

DIRECCIÓN

Executive / Direction

BONN	16
BELICE	22
TRENTO	28
ZURICH	34
OXFORD	40
SIENA	46
BARI	52

Designer:
SIGFRIDO BILBAO

BONN

DIRECCIÓN
Executive / Direction





BONN
 SILLÓN DE DIRECCIÓN

Sillón de dirección ergonómico alto con cabecero. Asiento y respaldo con estructura metálica, tapizados sobre espuma inyectada de alta densidad. Brazos (tapizados en su parte superior) y base (de 5 radios con ruedas blandas de 65mm. de diámetro) de aluminio pulido brillo. Mecanismo sincro autopésante con bloqueo de 5 posiciones (Antishock). Disponible en respaldo alto (con o sin cabecero), medio o bajo (confidente con base fija de 4 radios en aluminio pulido brillo). Opcionalmente puede incorporar un modelo de brazo de aluminio pintado a juego con las bases..

BONN
 DIRECTIONAL ARMCHAIR

Directional ergonomic armchair with headrest. Seat and back made with inner metal frame, upholstered in high density injected foam. Polished aluminium armrest upholstered on top and polished aluminium base with 65mm diameter soft castors. Auto-weight synchro mechanism with 5 positions (Antishock). Available in high (with or without headrest), medium or low backrest (visitor with 4 points fixed polished aluminium base) Available with aluminium armrest painted as bases.

BONN
 FAUTEUIL DE DIRECTION

Fauteuil de direction haut ergonomique avec tête. L'assise et le dossier tapissés sur une structure métallique habillée avec une mousse injectée de haute densité. Accoudoirs (tapissés sur la partie supérieure) et le piètement (de 5 radios avec des roues molles de 65 mm de diamètre) d'aluminium poli avec éclat. Mécanisme autopésante avec blocage de 5 positions (Antishock). C'est disponible dans un dossier haut (avec o sans tête) moyen o bas. (Confident avec un piètement de 4 radios en aluminium poli avec éclat). Optionnellement ou peut incorporer un modèle des accoudoirs en aluminium peint à jeu avec les piètements.



BONN A
 115/127
 57
 50

BONN
 105/117
 57
 50

BONN B
 95/107
 57
 50

BONN P
 95/107
 57
 50

Altura / Height / Haut
 Anchura / Width / Large
 Fondo / Depth / Fond

ACABADOS BRAZOS Y BASES / ARMS AND SWIVEL FINISHES / FINITIONS D'ACCOUDOIRS ET PIÈTEMENTS

ALUMINIO PULIDO	BLANCO	NEGRO
Polished Aluminum Aluminium Poli	White Blanc	Black Noir

OTROS ACABADOS / OTHER FINISHES / AUTRES FINITIONS

Acabados y tipologías de bases, ruedas, brazos y mecanismos:
 Consultar tarifa.

Finishes, types of bases, castors, armrest and mechanisms.
 Check price list.

Finitions et types de piètement, roués, accoudoirs et mécanismes.
 Consulter le tarif.

TAPICERÍAS / UPHOLSTERY / TAPISSERIES

Las sillas se pueden tapizar con cualquier tejido o piel de nuestro muestrario (pág. 294) o con tejidos suministrados por el cliente.

Chairs can be upholstered in a any fabric or leather of our sample book (pag. 294) or in COM.

Les chaises peuvent être tapissées avec n'importe quel tissu o cuir de notre échantillonnage (pag. 294) Ou avec les tissus fournis par le client.

BELICE

DIRECCIÓN

Executive / Direction



BELICE

DIRECCIÓN
Executive / Direction



BELICE
 SILLÓN DE DIRECCIÓN

Sillón de dirección ergonómico alto. Estructura de monocarcasa de haya tapizada sobre espuma inyectada de alta densidad. Brazos (tapizados en su parte superior) y base (de 5 radios con ruedas blandas de 65mm. de diámetro) de aluminio pulido brillo. Mecanismo basculante-relax con multi bloqueo (Antishock). Disponible en respaldo alto (con o sin cabecero), o bajo (confidente con base patín cromado y brazo con parte superior tapizada).

BELICE
 DIRECTIONAL ARMCHAIR

High ergonomic executive chair. Made with a single shell of beech wood upholstered in high density injected foam. Polished aluminium armrest upholstered on top and polished aluminium base with 65mm diameter soft castors. Tilting-relax mechanism (Antishock). Available in high (with or without headrest), or low backrest (visitor with chromed cantilever and armrest upholstered on top).

BELICE
 FAUTEUIL DE DIRECTION

Fauteuil de direction haut ergonomique. Structure de monocarcasse de hêtre tapissée sur une mousse injectée de haute densité. Accoudoirs (Tapissés sur la partie supérieure) et le piètement (de 5 radios avec des roues molles de 65 mm de diamètre) d'aluminium poli avec éclat. Mécanisme basculant – relax avec multi blocage (Antishock). Disponible dans un dossier haut (avec o sans tête) o bas (confident avec le piètement luge chromé) et l'accoudoirs tapissé sur la partie supérieure.



BELICE
 130/142
 61
 56



BELICE B
 105/117
 61
 56



BELICE P
 100
 63
 56

Altura / Height / Haut
Anchura / Width / Large
Fondo / Depth / Fond

OTROS ACABADOS / OTHER FINISHES / AUTRES FINITIONS

Acabados y tipologías de bases, ruedas, brazos y mecanismos:
 Consultar tarifa.

Finishes, types of bases, castors, armrest and mechanisms.
 Check price list.

Finitions et types de piètement, roués, accoudoirs et mécanismes.
 Consulter le tarif.

TAPICERÍAS / UPHOLSTERY / TAPISSERIES

Las sillas se pueden tapizar con cualquier tejido o piel de nuestro muestrario (pág. 294) o con tejidos suministrados por el cliente.

Chairs can be upholstered in a any fabric or leather of our sample book (pag. 294) or in COM.

Les chaises peuvent être tapissées avec n'importe quel tissu ou cuir de notre échantillonnage (pag. 294) Ou avec les tissus fournis par le client.

TRENTO

DIRECCIÓN

Executive / Direction



TRENTO

DIRECCIÓN
Executive / Direction



TRENTO
 SILLÓN DE DIRECCIÓN

Sillón de dirección ergonómico alto. Estructura de monocarcasa de haya tapizada sobre espuma inyectada de alta densidad. Brazos y base (de 5 radios con ruedas blandas de 65mm. de diámetro) de aluminio pulido brillo. Mecanismo basculante-relax con multi bloqueo (Antishock). Disponible en respaldo alto, bajo y confidente con base fija de 4 radios cromada (TRENTO PA) o con base de patín cromado (TRENTO PC).

TRENTO
 DIRECTIONAL ARMCHAIR

High ergonomic executive chair. Made with a single shell of beech wood upholstered in high density injected foam. Polished aluminium armrest and base (with 5 spokes with 65mm diameter soft wheels). Tilt-relax mechanism with multiblocking (Antishock). Available in high, low and confident backrests with a fixed base with 4 chromed spokes (TRENTO PA) or with a chromed sled base (TRENTO PC).

TRENTO
 FAUTEUIL DE DIRECTION

Fauteuil de direction haut ergonomique. Structure de monocarcasse de hêtre tapissée sur une mousse injectée de haute densité. Accoudoirs et base (à 5 rayons avec roues souples de diamètre 65 mm) en aluminium poli brillant. Mécanisme Tilt-relax avec multiblocage (Antishock). Disponible en dossier haut, bas et confiant avec une base fixe à 4 branches chromées (TRENTO PA) ou avec une base luge chromée (TRENTO PC).

TRENTO A
 125/137
 57
 51

TRENTO B
 94/106
 57
 51

TRENTO PC
 96
 57
 51

TRENTO PA
 92/104
 57
 51

Altura / Height / Haut
Anchura / Width / Large
Fondo / Depth / Fond

OTROS ACABADOS / OTHER FINISHES / AUTRES FINITIONS

Acabados y tipologías de bases, ruedas, brazos y mecanismos:
 Consultar tarifa.

Finishes, types of bases, castors, armrest and mechanisms.
 Check price list.

Finitions et types de piètement, roués, accoudoirs et mécanismes.
 Consulter le tarif.

TAPICERÍAS / UPHOLSTERY / TAPISSERIES

Las sillas se pueden tapizar con cualquier tejido o piel de nuestro muestrario (pág. 294) o con tejidos suministrados por el cliente.

Chairs can be upholstered in a any fabric or leather of our sample book (pag. 294) or in COM.

Les chaises peuvent être tapissées avec n'importe quel tissu ou cuir de notre échantillonnage (pag. 294) Ou avec les tissus fournis par le client.

Designer:
STEFANO SANDONÀ E SABRINA BETTINI

ZURICH

DIRECCIÓN
Executive / Direction



ZURICH

DIRECCIÓN
Executive / Direction



ZURICH
 SILLÓN DE DIRECCIÓN

Silla ergonómica con estructura inyectada en nylon y fibra de vidrio. Mecanismo oscilante con bloqueo en posición de inicio. Malla de diferentes colores fabricada en poliéster (70%) y poliamida (30%). Dispone de diferentes opciones de bases con ruedas o topes antideslizantes.

ZURICH
 DIRECTIONAL ARMCHAIR

Ergonomic chair made in injected structure in nylon and fiber glass. Tilting mechanism, lock the seat in neutral position. Different colors mesh, made in 70% polyester and 30% polyamide. Available with different bases or stoppers.

ZURICH
 FAUTEUIL DE DIRECTION

Siège ergonomique avec la structure injectée à un nylon et à une fibre de verre. Mécanisme oscillant dans un blocage dans une position de commencement. Mailles de différents couleurs fabriquée dans polyester (70%) et polyamide (30%). Il y a divers options de piétement avec roues ou arrêts antidérapants.



ZURICH 1
90/102
50
57

ZURICH 2
90/102
60
57

ZURICH 3
90/102
50
57

ZURICH 4
90/102
60
57

Altura / Height / Haut
Anchura / Width / Large
Fondo / Depth / Fond

ACABADOS MALLAS / MESH FINISHES / FINITIONS MAILLES

BLANCO	NEGRO	GRIS	MARRÓN	TURQUESA
White Blanc	Black Noir	Grey Gris	Brown Marron	Turquoise Turquoise

ACABADOS PLÁSTICOS / PLASTIC FINISHES / FINITIONS PLASTIQUES

BLANCO	NEGRO
White Blanc	Black Noir

ACABADOS BASES / BASES FINISHES / FINITIONS PIÉTEMENTS

ALUMINIO PULIDO	BLANCO	NEGRO
Polished Aluminum Aluminium Poli	White Blanc	Black Noir

OTROS ACABADOS / OTHER FINISHES / AUTRES FINITIONS

Acabados y tipologías de bases, ruedas, brazos y mecanismos:
Consultar tarifa.

Finishes, types of bases, castors, armrest and mechanisms.
Check price list.

Finitions et types de piétement, roués, accoudoirs et mécanismes.
Consulter le tarif.

TAPICERÍAS / UPHOLSTERY / TAPISSERIES

Las sillas se pueden tapizar con cualquier tejido o piel de nuestro muestrario (pág. 294) o con tejidos suministrados por el cliente.

Chairs can be upholstered in a any fabric or leather of our sample book (pag. 294) or in COM.

Les chaises peuvent être tapissées avec n'importe quel tissu ou cuir de notre échantillonnage (pag. 294) Ou avec les tissus fournis par le client.

Designer:
STEFANO SANDONÀ

OXFORD

DIRECCIÓN
Executive / Direction



OXFORD

DIRECCIÓN
Executive / Direction



OXFORD
SILLÓN DE DIRECCIÓN

Sillón de dirección ergonómico alto. Asiento y respaldo con estructura metálica, tapizados sobre espuma inyectada de alta densidad. Brazos y base (de 5 radios con ruedas blandas de 65mm. de diámetro) de aluminio pulido brillo. Mecanismo sincro autopésante con bloqueo de 5 posiciones (Antishock). Disponible en respaldo alto, medio o bajo (confidente con base fija de 4 radios en aluminio pulido brillo). Opcionalmente puede incorporar una pastilla tapizada sobre los brazos.

OXFORD
DIRECTIONAL ARMCHAIR

Directional ergonomic armchair. Seat and back made with inner metal frame, upholstered in high density injected foam. Polished aluminium armrest and base (5 points with 65mm diameter soft castors). Auto-weight synchro mechanism 5 positions. (Antishock). Available in high, medium or low backrest (visitor with 4 points fixed polished aluminium base). Optionally, armrest can be upholstered on top.

OXFORD
FAUTEUIL DE DIRECTION

Fauteuil de direction haut ergonomique. Dossier et assise à structure métallique tapissé sur une mousse injectée d'une haute densité. Accoudoirs et piètement (de 5 radios avec des roues molles de 65 mm de diamètre) de aluminium poli. Mécanisme autopésante avec blocage de 5 positions (Antishock). Disponible dans un dossier haut, moyen ou bas (confidente avec un piètement fixe de 4 radios en aluminium poli éclat). Optionnellement on peut incorporer des plaquettes tapissées sur les bras.



OXFORD
118/130
66
57

OXFORD B
105/117
66
57

OXFORD P
92
66
57

Altura / Height / Haut
Anchura / Width / Large
Fondo / Depth / Fond

OTROS ACABADOS / OTHER FINISHES / AUTRES FINITIONS

Acabados y tipologías de bases, ruedas, brazos y mecanismos:
Consultar tarifa.

Finishes, types of bases, castors, armrest and mechanisms.
Check price list.

Finitions et types de piètement, roués, accoudoirs et mécanismes.
Consultar le tarif.

TAPICERÍAS / UPHOLSTERY / TAPISSERIES

Las sillas se pueden tapizar con cualquier tejido o piel de nuestro muestrario (pág. 294) o con tejidos suministrados por el cliente.

Chairs can be upholstered in a any fabric or leather of our sample book (pag. 294) or in COM.

Les chaises peuvent être tapissées avec n'importe quel tissu ou cuir de notre échantillonnage (pag. 294) Ou avec les tissus fournis par le client.

Designer:
ANGELO DIDONÉ E MASSIMO COSTAGLIA

SIENA

DIRECCIÓN
Executive / Direction





SIENA
SILLÓN DE DIRECCIÓN

Sillón ergonómico direccional. Mecanismo sincro autopesante con bloqueo de 5 posiciones (Antishock). Regulación en profundidad y en altura del asiento. Asiento y respaldo (con cabezal opcional) tapizado sobre espuma inyectada o respaldo en malla 100% poliéster. Tensor lumbar regulable en altura (en ambas versiones) y brazos regulables en altura. Base de poliamida reforzada con fibra de vidrio (opcionalmente en aluminio pulido). Disponible con cabezal tapizado solo en la versión de respaldo tapizado.

SIENA
DIRECTIONAL ARMCHAIR

Directional ergonomic armchair. Auto-weight synchro mechanism 5 positions (Antishock), also includes depth adjustment seat. Back (with or without headrest) and seat upholstered in high density foam or 100% polyester mesh in back. Tensor adjustable lumbar height (with mesh and upholstered back), height adjustable arms. Polyamide fiberglass base. Available also polished aluminium base. Available headrest only when the back is upholstered.

SIENA
FAUTEUIL DE DIRECTION

Fauteuil ergonomique directionnel. Mécanisme synchrone autopésante avec blocage de 5 positions (antishock). Régulation dans une profondeur et dans hauteur d'assise. Assise et dossier (avec tête optionnel) tapissés avec mousse injectée ou un dossier en maille 100 % polyester. Tenseur lombaire réglable en hauteur (Dans les deux versions). Et accoudoirs réglables en hauteur. Piètement de polyamide renforcée avec fibre de verre. Optionnellement avec tête tapissé seulement pour la version de dossier tapissé.



SIENA A
120/132
66
50/57



SIENA
100/112
66
50/57



SIENA M
100/112
66
50/57

Altura / Height / Haut
Anchura / Width / Large
Fondo / Depth / Fond

ACABADOS MALLAS / MESH FINISHES / FINITIONS MAILLES

NEGRO



Black
Noir

ACABADOS ESTRUCTURA / STRUCTURE FINISHES / FINITIONS ESTRUCTURE

NEGRO



Black
Noir

OTROS ACABADOS / OTHER FINISHES / AUTRES FINITIONS

Acabados y tipologías de bases, ruedas, brazos y mecanismos:
Consultar tarifa.

Finishes, types of bases, castors, armrest and mechanisms.
Check price list.

Finitions et types de piètement, roués, accoudoirs et mécanismes.
Consulter le tarif.

TAPICERÍAS / UPHOLSTERY / TAPISERIES

Las sillas se pueden tapizar con cualquier tejido o piel de nuestro muestrario (pág. 294) o con tejidos suministrados por el cliente.

Chairs can be upholstered in a any fabric or leather of our sample book (pag. 294) or in COM.

Les chaises peuvent être tapissées avec n'importe quel tissu ou cuir de notre échantillonnage (pag. 294) Ou avec les tissus fournis par le client.

BARI

DIRECCIÓN
Executive / Direction



BARI

DIRECCIÓN
Executive / Direction



BARI
 SILLÓN DE DIRECCIÓN

Sillón direccional ergonómico con reposacabezas opcional. Mecanismo sincro autopesante con bloqueo de 5 posiciones (Antishock). Regulación en profundidad y en altura del asiento. Regulación en altura del respaldo. Espuma inyectada de alta densidad sobre alma metálica. Brazos fijos, regulables en altura, 2D ó 3D opcionales. Base de cinco puntas en poliamida reforzada con fibra de vidrio (opcionalmente en aluminio pulido). Respaldo con una pequeña carcasa plástica vista o totalmente tapizado.

BARI
 DIRECTIONAL ARMCHAIR

Directional ergonomic armchair (available with headrest) Auto-weight synchro mechanism 5 positions (Antishock), also includes depth adjustment seat. Height adjustment of the backrest. Upholstered in high density foam over a inner metal structure. Available with fixed, height adjustable, 2D or 3D adjustable arms. Polyamide fiberglass base 5 points. Available also polished aluminium base. The backrest can be upholstered completely.

BARI
 FAUTEUIL DE DIRECTION

Fauteuil ergonomique directionnel avec tête optionnel. Mécanisme synchrone autopésante avec blocage de 5 positions (Antishock). Régulation dans une profondeur et dans hauteur d'assise. Réglable dans la hauteur du dossier. Mousse haute densité injectée. Accoudoirs fixes, réglables en hauteur, 2D ou 3D optionnels. Piètement de polyamide à cinq branches renforcée avec fibre de verre. (Optionnellement en aluminium poli). Dossier avec une petite carcasse plastique vue ou totalement tapissé.

**BARI A**

125/137

50

54/61

BARI

105/115

50

54/61

Altura / Height / Haut

Anchura / Width / Large

Fondo / Depth / Fond

OTROS ACABADOS / OTHER FINISHES / AUTRES FINITIONS

Acabados y tipologías de bases, ruedas, brazos y mecanismos:
Consultar tarifa.

Finishes, types of bases, castors, armrest and mechanisms.
Check price list.

Finitions et types de piètement, roués, accoudoirs et mécanismes.
Consulter le tarif.

TAPICERÍAS / UPHOLSTERY / TAPISSERIES

Las sillas se pueden tapizar con cualquier tejido o piel de nuestro muestrario (pág. 294) o con tejidos suministrados por el cliente.

Chairs can be upholstered in a any fabric or leather of our sample book (pag. 294) or in COM.

Les chaises peuvent être tapissées avec n'importe quel tissu ou cuir de notre échantillonnage (pag. 294) Ou avec les tissus fournis par le client.

LOS LOGROS DE UNA ORGANIZACIÓN, SON LOS RESULTADOS DE ESFUERZO COMBINADO DE CADA INDIVIDUO.

VINCE LOMBARDI

"Lombardi es considerado como uno de los mejores entrenadores de fútbol americano de la historia"

"THE ACHIEVEMENTS OF AN ORGANIZATION, ARE THE RESULTS OF THE COMBINED EFFORT OF EACH INDIVIDUAL."

Vince Lombardi

"Lombardi is considered one of the best football coaches in history."

"LES RÉUSSITES D'UNE ORGANISATION SONT LES RÉSULTATS DE L'EFFORT COMBINÉ DE CHAQUE PERSONNE."

Vince Lombardi

"Lombardi est considéré comme l'un des meilleurs entraîneurs de football américain de l'histoire."

OPERATIVAS

Operative / Operative

BREMEN	60
CÓRCEGA	66
NICEA	72
PARMA	78
ROMA	84
BERNA	90
PALMA	94
AZORES	100
ODESA	106
ATENAS	112
SOFÍA	118

Designer:
CLAUDIO BELLINI

BREMEN

OPERATIVA
Operative / Operative



BREMEN

OPERATIVA
Operartive / Operartive



BREMEN
 SILLA OPERATIVA

Silla ergonómica con respaldo de malla técnica en color negro y regulable en altura, enfundada en una estructura perimetral de poliamida reforzada con fibra de vidrio. Tensor lumbar regulable en altura y profundidad. Mecanismo sincro autopésante con regulación lateral y con bloqueo de 5 posiciones (Antishock). Regulación del asiento en profundidad. Brazos regulables 4D incluidos. Base de cinco puntas en poliamida reforzada con fibra de vidrio.

BREMEN
 TASK CHAIR

Ergonomic chair with backrest in black technical mesh and adjustable in height, sheathed in a polyamide perimeter structure reinforced with fiberglass. Lumbar tensioner adjustable in height and depth. Auto-weight CONTROL synchro mechanism with lateral adjustment and 5-position lock (Antishock). Depth adjustment of the seat. 4D adjustable arms included. Five-point base in polyamide reinforced with fiberglass.

BREMEN
 SIÈGE OPERATIONNELLE

Chaise ergonomique avec dossier en résille technique noire et réglable en hauteur, gainée d'une structure périmétrique en polyamide renforcée de fibre de verre. Tendeur lombaire réglable en hauteur et en profondeur. Mécanisme synchro autopésant avec réglage latéral et blocage 5 positions (Antishock). Réglage en profondeur du siège. Accoudoirs réglables 4D inclus. Base à cinq points en polyamide renforcé de fibre de verre.



BREMEN
 106/118
 50
 46/53

Altura / Height / Haut
 Anchura / Width / Large
 Fondo / Depth / Fond

ACABADOS MALLAS / MESH FINISHES / FINITIONS MAILLES

NEGRO



Black
 Noir

ACABADOS PLÁSTICOS Y BRAZOS

PLASTIC FINISHES AND ARMREST / FINITION DE PLASTIQUES ET ACCOUDOIRS

BLANCO



White
 Blanc

NEGRO



Black
 Noir

ACABADOS BASES / BASES FINISHES / FINITIONS PIÈTEMENTS

BLANCO



White
 Blanc

NEGRO



Black
 Noir

ALUMINIO PULIDO



Polished Aluminum
 Aluminium Poli

OTROS ACABADOS / OTHER FINISHES / AUTRES FINITIONS

Acabados y tipologías de bases, ruedas, brazos y mecanismos:
 Consultar tarifa.

Finishes, types of bases, castors, armrest and mechanisms.
 Check price list.

Finitions et types de piètement, roués, accoudoirs et mécanismes.
 Consulter le tarif.

TAPICERÍAS / UPHOLSTERY / TAPISSERIES

Las sillas se pueden tapizar con cualquier tejido o piel de nuestro muestrario (pág. 294) o con tejidos suministrados por el cliente.

Chairs can be upholstered in a any fabric or leather of our sample book (pag. 278) or in COM.

Les chaises peuvent être tapissées avec n'importe quel tissu ou cuir de notre échantillonnage (pag. 294) Ou avec les tissus fournis par le client.

CÓRCEGA

OPERATIVA

Operative / Operative



CÓRCEGA

OPERATIVA
Operative / Operative



CÓRCEGA
 SILLA OPERATIVA

Silla ergonómica con respaldo de malla técnica, en diferentes colores, clipada a una estructura perimetral inyectada en poliamida reforzada con fibra de vidrio. Opción con cabecero tapizado. Mecanismo sincro con bloqueo de 5 posiciones (Antishock). Regulación del asiento en profundidad. Tensur lumbar regulable en altura. Brazos fijos, regulables en altura, 2D ó 3D opcionales. Base de cinco puntas en poliamida reforzada con fibra de vidrio.

CÓRCEGA
 TASK CHAIR

Ergonomic Chair with technical mesh (different colors) clipped in a perimeter structure injected with polyamide reinforced with fiberglass. Available with upholstered headrest. Synchro mechanism 5 position (antishock). Seat depth adjustable. Tensur lumbar height adjustable. Available with fixed, height adjustable, 2D or 3D adjustable arms. Base five-pointed polyamide reinforced with fiber glass

CÓRCEGA
 SIEGE OPERATIONNELLE

Siège ergonomique avec le dossier de maille technique en différents couleurs prise à une structure perimetral injectée en polyamide renforcée avec fibre en verre. Il y a une option de tête tapissée. Mécanisme synchro avec blocage de 5 positions (Antishock). Assise réglable en profondeur. Tenseur lombaire réglable en hauteur. Accoudoirs fixes, réglables en hauteur. 2D ou 3D optionnels. Piètement de polyamide renforcée avec fibre en verre à cinq branches.

CÓRCEGA A
 125/137
 50
 50/57

CÓRCEGA
 106/118
 50
 50/57

Altura / Height / Haut
 Anchura / Width / Large
 Fondo / Depth / Fond

ACABADOS MALLAS / MESH FINISHES / FINITIONS MAILLES

NEGRO	BURDEOS	AZUL	VERDE	MELOCOTÓN	VISÓN	GRIS
Black Noir	Bordeaux Bordeaux	Blue Bleu	Green Vert	Peach Pêche	Mink Vison	Gray Gris

ACABADOS PLÁSTICOS Y BRAZOS

PLASTIC FINISHES AND ARMREST / FINITION DE PLASTIQUES ET ACCOUDOIRS

NEGRO

 Black
 Noir

ACABADOS BASES / BASES FINISHES / FINITIONS PIÈTEMENTS
ALUMINIO PULIDO

 Polished Aluminum
 Aluminium Poli

NEGRO

 Black
 Noir

OTROS ACABADOS / OTHER FINISHES / AUTRES FINITIONS

Acabados y tipologías de bases, ruedas, brazos y mecanismos:
 Consultar tarifa.

Finishes, types of bases, castors, armrest and mechanisms.
 Check price list.

Finitions et types de piètement, roués, accoudoirs et mécanismes.
 Consulter le tarif.

TAPICERÍAS / UPHOLSTERY / TAPISSERIES

Las sillas se pueden tapizar con cualquier tejido o piel de nuestro muestrario (pág. 294) o con tejidos suministrados por el cliente.

Chairs can be upholstered in a any fabric or leather of our sample book (pag. 278) or in COM.

Les chaises peuvent être tapissées avec n'importe quel tissu ou cuir de notre échantillonnage (pag. 294) Ou avec les tissus fournis par le client.

NICEA

OPERATIVA
Operative / Operative



NICEA

OPERATIVA
Operartive / Operartive



NICEA
SILLA OPERATIVA

Silla ergonómica con respaldo de malla técnica, en diferentes colores, clipada a una estructura perimetral inyectada en poliamida reforzada con fibra de vidrio. Opción con cabecero tapizado. Mecanismo sincro con bloqueo de 5 posiciones (Antishock). Tensor lumbar regulable en altura. Brazos fijos, regulables en altura, 2D ó 3D opcionales. Base de cinco puntas en poliamida reforzada con fibra de vidrio. Regulación del asiento en profundidad opcional. Acabados plásticos blanco o negro.

NICEA
TASK CHAIR

Ergonomic Chair with technical mesh (different colors) clipped in a perimeter structure injected with polyamide reinforced with fiberglass. Available with upholstered headrest. Synchro mechanism 5 position (antishock). Tensor lumbar height adjustable. Available with fixed, height adjustable or 3D adjustable arms. Base five-pointed polyamide reinforced with fiber glass. Seat depth adjustment optional. Plastic finishes in black or white

NICEA
SIEGE OPERATIONNELLE

Siège ergonomique avec le dossier de maille technique en différents couleurs prise à une structure perimetral injectée en polyamide renforcée avec fibre en verre. Il y a une option de tête tapissée. Mécanisme synchro avec blocage de 5 positions (Antishock). Tenseur lombaire réglable en hauteur. Accoudoirs fixes, réglables en hauteur ou 3d optionnels. Piètement de polyamide renforcée avec fibre en verre à cinq branches. Assise réglable en profondeur optionnel. Finitions en plastique blanc ou noir.



NICEA A
128/140
51
49

NICEA
105/117
51
49

Altura / Height / Haut
Anchura / Width / Large
Fondo / Depth / Fond

ACABADOS MALLAS / MESH FINISHES / FINITIONS MAILLES

BLANCO	NEGRO	BURDEOS	AZUL	MARRÓN	GRIS
Blanco Blanco	Black Noir	Bordeaux Bordeaux	Blue Bleu	Brown Marron	Grey Gris

ACABADOS PLÁSTICOS Y BRAZOS
PLASTIC FINISHES AND ARMREST / FINITION DE PLASTIQUES ET ACCOUDOIRS

BLANCO	NEGRO
White Blanc	Black Noir

ACABADOS BASES / BASES FINISHES / FINITIONS PIÈTEMENTS

BLANCO	NEGRO	ALUMINIO PULIDO
White Blanc	Black Noir	Polished Aluminum Aluminium Poli

OTROS ACABADOS / OTHER FINISHES / AUTRES FINITIONS

Acabados y tipologías de bases, ruedas, brazos y mecanismos:
Consultar tarifa.

Finishes, types of bases, castors, armrest and mechanisms.
Check price list.

Finitions et types de piètement, roués, accoudoirs et mécanismes.
Consulter le tarif.

TAPICERÍAS / UPHOLSTERY / TAPISSERIES

Las sillas se pueden tapizar con cualquier tejido o piel de nuestro muestrario (pág. 294) o con tejidos suministrados por el cliente.

Chairs can be upholstered in a any fabric or leather of our sample book (pag. 294) or in COM.

Les chaises peuvent être tapissées avec n'importe quel tissu ou cuir de notre échantillonnage (pag. 294) Ou avec les tissus fournis par le client.

Designer:
MASSIMO COSTAGLIA

PARMA

OPERATIVA
Operative / Operative



PARMA

OPERATIVA
Operative / Operative



PARMA
SILLA OPERATIVA

Silla ergonómica con respaldo de malla técnica, en diferentes colores, con estructura perimetral inyectada en poliamida reforzada con fibra de vidrio (negra o blanca). Opción con cabecero tapizado. Mecanismo SINCRO de 4 posiciones mediante palanca (Antishock). Tensor lumbar regulable en altura. Brazos fijos, regulables en altura, 2D ó 3D opcionales. Base de cinco puntas en poliamida reforzada con fibra de vidrio.

PARMA
TASK CHAIR

Ergonomic Chair with technical mesh (different colors) clipped in a perimeterstructure injected with polyamide reinforced with fiberglass. Available with upholstered headrest. Synchro mechanism 4 position (antishock). Seat depth adjustment. Tensor lumbar height adjustable. Available with fixed, height adjustable, 2D or 3D adjustable arms. Base five-pointed polyamide reinforced with fiber glass.

PARMA
SIEGE OPERATIONNELLE

Siège ergonomique avec le dossier de maille technique en différents couleurs avec une structure perimetral injectée à une polyamide renforcée avec fibre en verre. (noir ou blanc). Il y a option de tête tapissée. Mécanisme synchro avec blocage de 4 positions (Antishock). Accoudoirs fixes, réglables en hauteur, 2D ou 3D optionnels. Piètement de polyamide renforcée avec fibre de verre à cinq branches.



PARMA A
122/135
52
56

PARMA
107/110
52
56

Altura / Height / Haut
Anchura / Width / Large
Fondo / Depth / Fond

ACABADOS MALLAS / MESH FINISHES / FINITIONS MAILLES

BLANCO	NEGRO	BURDEOS	AZUL	VERDE	MELOCOTÓN	VISÓN	GRIS
Blanco Blanco	Black Noir	Bordeaux Bordeaux	Blue Bleu	Green Vert	Peach Pêche	Mink Vison	Gray Gris

ACABADOS PLÁSTICOS Y BRAZOS

PLASTIC FINISHES AND ARMREST / FINITION DE PLASTIQUES ET ACCOUDOIRS

NEGRO	BLANCO
Black Noir	White Blanc

ACABADOS BASES / BASES FINISHES / FINITIONS PIÈTEMENTS

ALUMINIO PULIDO	NEGRO	BLANCO
Polished Aluminum Aluminium Poli	Black Noir	White Blanc

OTROS ACABADOS / OTHER FINISHES / AUTRES FINITIONS

Acabados y tipologías de bases, ruedas, brazos y mecanismos:
Consultar tarifa.

Finishes, types of bases, castors, armrest and mechanisms.
Check price list.

Finitions et types de piètement, roués, accoudoirs et mécanismes.
Consulter le tarif.

TAPICERÍAS / UPHOLSTERY / TAPISSERIES

Las sillas se pueden tapizar con cualquier tejido o piel de nuestro muestrario (pág. 294) o con tejidos suministrados por el cliente.

Chairs can be upholstered in a any fabric or leather of our sample book (pag. 294) or in COM.

Les chaises peuvent être tapissées avec n'importe quel tissu ou cuir de notre échantillonnage (pag. 294) Ou avec les tissus fournis par le client.

Designer:
SCAGNELLATO

ROMA

OPERATIVA
Operative / Operative



ROMA

OPERATIVA
Operartive / Operartive



ROMA
SILLA OPERATIVA

Silla ergonómica con respaldo de malla técnica, en diferentes colores, clipada a una estructura perimetral inyectada en poliamida reforzada con fibra de vidrio. Disponible en versión tapizada con trasera plástica o tapizada. Opción con cabecero tapizado. Mecanismo sincro con bloqueo de 5 posiciones (Antishock). Regulación del asiento en profundidad. Tensor lumbar regulable en altura. Brazos fijos, regulables en altura, 2D ó 3D opcionales. Base de cinco puntas en poliamida reforzada con fibra de vidrio. Acabados plásticos blanco o negro.

ROMA
TASK CHAIR

Ergonomic Chair with technical mesh (different colors) clipped in a perimeter structure injected with polyamide reinforced with fiberglass. Available with upholstered headrest. Synchro mechanism 5 position (antishock). Seat depth adjustment. Tensor lumbar height adjustable. Available with, fixed, height adjustable or 3D adjustable arms. Base five-pointed polyamide reinforced with fiber glass. Plastic finishes in black or white.

ROMA
SIEGE OPERATIONNELLE

Siège ergonomique avec le dossier de maille technique en différents couleurs prise à une structure perimetral injectée à une polyamide renforcée avec fibre en verre. Il y a une option de tête tapissée. Mécanisme synchro avec blocage de 5 positions (Antishock). Assise réglable en profondeur. Tenseur lombaire réglable en hauteur. Accoudoirs fixes, réglables en hauteur ou 3d optionnels. Piètement de polyamide renforcée avec fibre en verre à cinq branches. Finitions en plastique blanc ou noir..



ROMA M / CABECERO
125/137
48-52
51

ROMA M
105/117
48-52
51

ROMA / CABECERO
125/137
48-52
51

ROMA
105/117
48-52
51

Altura / Height / Haut
Anchura / Width / Large
Fondo / Depth / Fond

ACABADOS MALLAS / MESH FINISHES / FINITIONS MAILLES

BLANCO	NEGRO	BURDEOS	AZUL	VERDE	MELOCOTÓN	VISÓN	GRIS
Blanco Blanco	Black Noir	Bordeaux Bordeaux	Blue Bleu	Green Vert	Peach Pêche	Mink Vison	Grey Gris

ACABADOS PLÁSTICOS Y BRAZOS
PLASTIC FINISHES AND ARMREST / FINITION DE PLASTIQUES ET ACCOUDOIRS

NEGRO	BLANCO
Black Noir	White Blanc

ACABADOS BASES / BASES FINISHES / FINITIONS PIÈTEMENTS

ALUMINIO PULIDO	NEGRO	BLANCO
Polished Aluminum Aluminium Poli	Black Noir	White Blanc

OTROS ACABADOS / OTHER FINISHES / AUTRES FINITIONS

Acabados y tipologías de bases, ruedas, brazos y mecanismos: Consultar tarifa.

Finishes, types of bases, castors, armrest and mechanisms. Check price list.

Finitions et types de piètement, roués, accoudoirs et mécanismes. Consulter le tarif.

TAPICERÍAS / UPHOLSTERY / TAPISSERIES

Las sillas se pueden tapizar con cualquier tejido o piel de nuestro muestrario (pág. 294) o con tejidos suministrados por el cliente.

Chairs can be upholstered in a any fabric or leather of our sample book (pag. 294) or in COM.

Les chaises peuvent être tapissées avec n'importe quel tissu ou cuir de notre échantillonnage (pag. 294) Ou avec les tissus fournis par le client.

Designer:
SI-DESIGN

BERNA

OPERATIVA
Operative / Operative



BERNA
SILLA OPERATIVA

Silla ergonómica con respaldo de malla técnica, en diferentes colores, clipada a una estructura perimetral inyectada en poliamida reforzada con fibra de vidrio. Mecanismo sincro con bloqueo de 5 posiciones (Antishock). Tensor lumbar regulable en altura. Brazos fijos, regulables en altura, 2D ó 3D opcionales. Base de cinco puntas en poliamida reforzada con fibra de vidrio. Regulación del asiento en profundidad opcional. Acabados plásticos blanco o negro..

BERNA
TASK CHAIR

Ergonomic Chair with technical mesh (different colors) clipped in a perimeter structure injected with polyamide reinforced with fiberglass. Synchro mechanism 5 position (antishock). Tensor lumbar height adjustable. Available with, fixed, height adjustable or 3D adjustable arms. Base five-pointed polyamide reinforced with fiber glass. Seat depth adjustment optional. Plastic finishes in black or white.

BERNA
SIÈGE OPERATIONNELLE

Siège ergonomique avec le dossier de maille technique en différents couleurs prise à une structure perimetral injectée à une polyamide renforcée avec fibre en verre. Mécanisme synchro avec blocage de 5 positions (Antishock). Tenseur lombaire réglable en hauteur. Accoudoirs fixes, réglables en hauteur ou 3d optionnels. Piètement de polyamide renforcée avec fibre en verre à cinq branches. Assise réglable en profondeur optionnel. Finitions en plastique blanc ou noir



BERNA
 99/111
 51
 46

Altura / Height / Haut
Anchura / Width / Large
Fondo / Depth / Fond

ACABADOS MALLAS / MESH FINISHES / FINITIONS MAILLES

BLANCO	NEGRO	BURDEOS	AZUL	VERDE	MELOCOTÓN	VISÓN	GRIS
Blanco Blanco	Black Noir	Bordeaux Bordeaux	Blue Bleu	Green Vert	Peach Pêche	Mink Vison	Grey Gris

ACABADOS PLÁSTICOS Y BRAZOS

PLASTIC FINISHES AND ARMREST / FINITION DE PLASTIQUES ET ACCOUDOIRS

NEGRO	BLANCO
Black Noir	White Blanc

ACABADOS BASES / BASES FINISHES / FINITIONS PIÈTEMENTS

ALUMINIO PULIDO	NEGRO	BLANCO
Polished Aluminum Aluminium Poli	Black Noir	White Blanc

OTROS ACABADOS / OTHER FINISHES / AUTRES FINITIONS

Acabados y tipologías de bases, ruedas, brazos y mecanismos:
Consultar tarifa.

Finishes, types of bases, castors, armrest and mechanisms.
Check price list.

Finitions et types de piètement, roués, accoudoirs et mécanismes.
Consulter le tarif.

TAPICERÍAS / UPHOLSTERY / TAPISSERIES

Las sillas se pueden tapizar con cualquier tejido o piel de nuestro muestrario (pág. 294) o con tejidos suministrados por el cliente.

Chairs can be upholstered in a any fabric or leather of our sample book (pag. 294) or in COM.

Les chaises peuvent être tapissées avec n'importe quel tissu ou cuir de notre échantillonnage (pag. 294) Ou avec les tissus fournis par le client.

PALMA

OPERATIVA
Operative / Operative



PALMA

OPERATIVA
Operartive / Operartive



PALMA
SILLA OPERATIVA

Silla giratoria con respaldo de malla técnica en color negro clipada a una estructura perimetral inyectada en poliamida reforzada con fibra de vidrio. Asiento tapizado. Opción silla giratoria con mecanismo oscilante con bloqueo en posición de inicio (diferentes bases disponibles) y opción patín pintado en color blanco o negro. Brazos fijos incluidos. Acabados plásticos blanco o negro.

PALMA
TASK CHAIR

Swivel chair with backrest in black technical mesh clipped to a perimeter structure injected in polyamide reinforced with fiberglass. Upholstered seat. Swivel chair option with oscillating mechanism with lock in the starting position (different bases available) and white or black painted sled base option. Fixed arms included. White or black plastic finishes.

PALMA
SIEGE OPERATIONNELLE

Chaise pivotante avec dossier en résille technique noire clipsée sur une structure périmétrique injectée en polyamide renforcé de fibre de verre. Assise rembourrée. Option chaise pivotante avec mécanisme oscillant avec blocage en position de départ (différentes bases disponibles) et option base luge peinte en blanc ou noir. Accoudoirs fixes inclus. Finitions en plastique blanc ou noir.

**PALMA**

85/97

59

48

PALMA P

90

59

48

Altura / Height / Haut

Anchura / Width / Large

Fondo / Depth / Fond

ACABADOS MALLAS / MESH FINISHES / FINITIONS MAILLES

NEGRO

Black
Noir**ACABADOS PLÁSTICOS Y BRAZOS**

PLASTIC FINISHES AND ARMREST / FINITION DE PLASTIQUES ET ACCOUDOIRS

NEGRO

Black
Noir

BLANCO

White
Blanc**ACABADOS BASES / BASES FINISHES / FINITIONS PIÈTEMENTS**

ALUMINIO PULIDO

Polished Aluminum
Aluminium Poli

NEGRO

Black
Noir

BLANCO

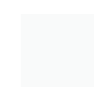
White
Blanc**OTROS ACABADOS / OTHER FINISHES / AUTRES FINITIONS**

Acabados y tipologías de bases, ruedas, brazos y mecanismos:
Consultar tarifa.

Finishes, types of bases, castors, armrest and mechanisms.
Check price list.

Finitions et types de piètement, roués, accoudoirs et mécanismes.
Consulter le tarif.

TAPICERÍAS / UPHOLSTERY / TAPISSERIES

Las sillas se pueden tapizar con cualquier tejido o piel de nuestro muestrario (pág. 294) o con tejidos suministrados por el cliente.

Chairs can be upholstered in a any fabric or leather of our sample book (pag. 294) or in COM.

Les chaises peuvent être tapissées avec n'importe quel tissu ou cuir de notre échantillonnage (pag. 294) Ou avec les tissus fournis par le client.



AZORES

OPERATIVA
Operative / Operative



AZORES

OPERATIVA
Operative / Operative



AZORES
SILLA OPERATIVA

Sillón ergonómico con asiento y respaldo tapizado. Opción con cabecero tapizado. Mecanismo sincro con bloqueo de 5 posiciones (Antishock). Regulación del asiento en profundidad opcional. Respaldo regulable en altura mediante sistema de cremallera. Brazos fijos, regulables en altura, 2D ó 3D opcionales. Base de cinco puntas en poliamida reforzada con fibra de vidrio. Carcasas plásticas, brazos y base disponibles en color blanco.

AZORES
TASK CHAIR

Ergonomic armchair, upholstered seat and back. Available with upholstered headrest. Synchro mechanism 5 positions (Antishock).available with depth adjustment seat. Height adjustable seat with gas piston and height- adjustable backrest with rack system. Available with fixed, height adjustable, 2D or 3D adjustable arms. Base five-pointed polyamide reinforced with fiber glass. Shells, arms and base available in white.

AZORES
SIEGE OPERATIONNELLE

Siège ergonomique avec assise et dossier tapissée. Option de tête tapissée. Mécanisme Synchrone avec blocage de 5 positions (antishock). Régulation du assise en profondeur optionnelle. Dossier réglable en hauteur ou moyen d'un système de fermeture éclair. Accoudoirs fixes, réglables en hauteur, 2D ou 3D optionnels. Piètement de 5 branches en polyamide renforcée avec fibre en verre. Des carcasses plastiques, accoudoirs et piètement disponible en couleur blanc.

**AZORES A**

123/135
52
57

AZORES

102/114
52
57

Altura / Height / Haut
Anchura / Width / Large
Fondo / Depth / Fond

**ACABADOS PLÁSTICOS Y BRAZOS**

PLASTIC FINISHES AND ARMREST / FINITION DE PLASTIQUES ET ACCOUDOIRS

NEGRO

Black
Noir

BLANCO

White
Blanc**ACABADOS BASES / BASES FINISHES / FINITIONS PIÈTEMENTS**

ALUMINIO PULIDO

Polished Aluminum
Aluminium Poli

NEGRO

Black
Noir

BLANCO

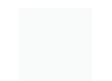
White
Blanc**OTROS ACABADOS / OTHER FINISHES / AUTRES FINITIONS**

Acabados y tipologías de bases, ruedas, brazos y mecanismos:
Consultar tarifa.

Finishes, types of bases, castors, armrest and mechanisms.
Check price list.

Finitions et types de piètement, roués, accoudoirs et mécanismes.
Consulter le tarif.

TAPICERÍAS / UPHOLSTERY / TAPISSERIES

Las sillas se pueden tapizar con cualquier tejido o piel de nuestro muestrario (pág. 294) o con tejidos suministrados por el cliente.

Chairs can be upholstered in a any fabric or leather of our sample book (pag. 294) or in COM.

Les chaises peuvent être tapissées avec n'importe quel tissu ou cuir de notre échantillonnage (pag. 294) Ou avec les tissus fournis par le client.

ODESA

OPERATIVA

Operative / Operative



ODESA

OPERATIVA
Operartive / Operartive



ODESA
SILLA OPERATIVA

Silla ergonómica con asiento y respaldo tapizado. Refuerzo lumbar regulable en altura. Mecanismo sincro con bloqueo de 5 posiciones (Antishock). Regulación del asiento en profundidad. Respaldo regulable en altura mediante sistema de cremallera. Brazos fijos, regulables en altura, 2D ó 3D opcionales. Base de cinco puntas en poliamida reforzada con fibra de vidrio. Opción taburete giratorio.

ODESA
TASK CHAIR

Ergonomic chair, upholstered seat and back. Tensor adjustable lumbar height. Synchro mechanism position (Antishock). Depth adjustment seat. Backrest height adjustment by rack system. Available with fixed, height adjustable, 2D or 3D adjustable arms. Base five-pointed polyamide reinforced with fiber glass. Available stool version.

ODESA
SIEGE OPERATIONNELLE

Siège ergonomique avec assise et dossier tapissé. Un renfort lombaire réglable dans une hauteur. Mécanisme synchrone réglable dans une hauteur. Mécanisme synchrone avec blocage de 5 positions. (Antishock.) Régulation du assise en profondeur dossier réglable en hauteur au moyen d'un système de fermeture d'éclair. Accoudoirs fixes, réglables en hauteur, 2D ou 3D optionnels. Piètement de 5 branches en polyamide renforcée avec fibre de verre. Option de tabouret tournant.

ODESA
100/112
50
56/62

ODESA T
105/130
50
56/62

Altura / Height / Haut
Anchura / Width / Large
Fondo / Depth / Fond

ACABADOS PLÁSTICOS Y BRAZOS

PLASTIC FINISHES AND ARMREST / FINITION DE PLASTIQUES ET ACCOUDOIRS

NEGRO

Black
Noir

ACABADOS BASES / BASES FINISHES / FINITIONS PIÈTEMENTS
ALUMINIO PULIDO

Polished Aluminum
Aluminium Poli

NEGRO

Black
Noir

OTROS ACABADOS / OTHER FINISHES / AUTRES FINITIONS

Acabados y tipologías de bases, ruedas, brazos y mecanismos:
Consultar tarifa.

Finishes, types of bases, castors, armrest and mechanisms.
Check price list.

Finitions et types de piètement, roués, accoudoirs et mécanismes.
Consulter le tarif.

TAPICERÍAS / UPHOLSTERY / TAPISSERIES

Las sillas se pueden tapizar con cualquier tejido o piel de nuestro muestrario (pág. 294) o con tejidos suministrados por el cliente.

Chairs can be upholstered in a any fabric or leather of our sample book (pag. 294) or in COM.

Les chaises peuvent être tapissées avec n'importe quel tissu ou cuir de notre échantillonnage (pag. 294) Ou avec les tissus fournis par le client.

ATENAS

OPERATIVA

Operative / Operative





ATENAS
SILLA OPERATIVA

Silla ergonómica con asiento y respaldo tapizado. Mecanismo sincro con bloqueo de 5 posiciones (Antishock). Opción de contacto permanente. Regulación del asiento en profundidad opcional. Respaldo regulable en altura mediante sistema de cremallera. Brazos fijos, regulables en altura, 2D ó 3D opcionales. Base de cinco puntas en poliamida reforzada con fibra de vidrio. Opción taburete giratorio.

ATENAS
TASK CHAIR

Ergonomic chair, upholstered seat and back. Synchro mechanism 5 position (Antishock). Available in permanent contact mechanism and seat depth adjustment. Backrest height adjustment by rack system. Available with fixed, height adjustable, 2D or 3D adjustable arms. Base five-pointed polyamide reinforced with fiber glass. Available stool version.

ATENAS
SIEGE OPERATIONNELLE

Siège ergonomique avec assise et dossier tapissé mécanisme synchrone avec blocage de 5 positions (antishock). Il y a une option de contact permanente. Régulation du assise en profondeur optionnel. Dossier réglable en hauteur au moyen d'un système de fermeture éclair. Accoudoirs fixes, réglables en hauteur, 2D ou 3D optionnels. Piètement de 5 branches en polyamide enforcée avec fibre de verre. Option de tabouret girator.

ATENAS
100/112
52
55

ATENAS CP
100/112
52
55

ATENAS T
115/140
52
55

Altura / Height / Haut
Anchura / Width / Large
Fondo / Depth / Fond

ACABADOS PLÁSTICOS Y BRAZOS

PLASTIC FINISHES AND ARMREST / FINITION DE PLASTIQUES ET ACCOUDOIRS

NEGRO



Black
Noir

ACABADOS BASES / BASES FINISHES / FINITIONS PIÈTEMENTS

ALUMINIO PULIDO NEGRO



Polished Aluminum
Aluminium Poli



Black
Noir

OTROS ACABADOS / OTHER FINISHES / AUTRES FINITIONS

Acabados y tipologías de bases, ruedas, brazos y mecanismos:
Consultar tarifa.

Finishes, types of bases, castors, armrest and mechanisms.
Check price list.

Finitions et types de piètement, roués, accoudoirs et mécanismes.
Consulter le tarif.

TAPICERÍAS / UPHOLSTERY / TAPISERIES

Las sillas se pueden tapizar con cualquier tejido o piel de nuestro muestrario (pág. 294) o con tejidos suministrados por el cliente.

Chairs can be upholstered in a any fabric or leather of our sample book (pag. 294) or in COM.

Les chaises peuvent être tapissées avec n'importe quel tissu ou cuir de notre échantillonnage (pag. 294) Ou avec les tissus fournis par le client.

SOFÍA

OPERATIVA
Operative / Operative



SOFÍA
SILLA OPERATIVA

Silla ergonómica con asiento y respaldo tapizado. Mecanismo sincro con bloqueo de 5 posiciones (Antishock). Opción de contacto permanente. Regulación del asiento en profundidad opcional. Respaldo regulable en altura mediante sistema de cremallera. Brazos fijos, regulables en altura, 2D ó 3D opcionales. Base de cinco puntas en poliamida reforzada con fibra de vidrio. Opción taburete giratorio. Acabados plásticos blanco o negro.

SOFÍA
TASK CHAIR

Ergonomic chair, upholstered seat and back. Synchro mechanism 5 position (Antishock). Available in permanent contact mechanism and seat depth adjustment. Backrest height adjustment by rack system. Available with fixed, height adjustable or 3D adjustable arms. Base five-pointed polyamide reinforced with fiber glass. Available stool version. Plastic finishes in black or white.

SOFÍA
SIEGE OPERATIONNELLE

Siège ergonomique avec assise et dossier tapissé mécanisme synchrone avec blocage de 5 positions (antishock). Il y a une option de contact permanente. Régulation du assise en profondeur optionnel. Dossier réglable en hauteur au moyen d'un système de fermeture éclair. Accoudoirs fixes, réglables en hauteur ou 3D optionnels. Piètement de 5 branches en polyamide renforcée avec fibre de verre. Option de tabouret girator. Finitions en plastique blanc ou noir.



SOFIA
102/114
45
45

SOFIA CP
102/114
45
45

SOFIA TCP
117/132
45
45

Altura / Height / Haut
Anchura / Width / Large
Fondo / Depth / Fond

ACABADOS PLÁSTICOS Y BRAZOS

PLASTIC FINISHES AND ARMREST / FINITION DE PLASTIQUES ET ACCOUDOIRS

NEGRO



Black
Noir

BLANCO



White
Blanc

ACABADOS BASES / BASES FINISHES / FINITIONS PIÈTEMENTS

ALUMINIO PULIDO



Polished Aluminum
Aluminium Poli

NEGRO



Black
Noir

BLANCO



White
Blanc

OTROS ACABADOS / OTHER FINISHES / AUTRES FINITIONS

Acabados y tipologías de bases, ruedas, brazos y mecanismos: Consultar tarifa.

Finishes, types of bases, castors, armrest and mechanisms. Check price list.

Finitions et types de piètement, roués, accoudoirs et mécanismes. Consulter le tarif.

TAPICERÍAS / UPHOLSTERY / TAPISSERIES

Las sillas se pueden tapizar con cualquier tejido o piel de nuestro muestrario (pág. 294) o con tejidos suministrados por el cliente.

Chairs can be upholstered in a any fabric or leather of our sample book (pág. 294) or in COM.

Les chaises peuvent être tapissées avec n'importe quel tissu o cuir de notre échantillonnage (pág. 294) Ou avec les tissus fournis par le client.



ME ENSEÑARON QUE EL CAMINO DEL PROGRESO NO ERA RÁPIDO NI FÁCIL

MARIE CURIE

"Científica Polaca. Primera mujer en ganar un Premio Nobel y la primera persona, hombre o mujer, en ganar el Nobel dos veces (de Física y Química)."

"I WAS TAUGHT THAT THE PATH OF
PROGRESS WAS NEITHER SWIFT NOR
EASY."

Marie Curie

"Polish scientist. First woman to win a
Nobel Prize and the first person, male or
female, to win the Nobel twice (in Physics
and Chemistry)."

"ILS M'ONT MONTRÉ QUE LE CHEMIN
DU PROGRES N'ÉTAIT PAS RAPIDE ET
FACILE."

Marie Curie

"Une Polonaise Scientifique. Le premier
femme à gagner un prix nobel. Et la première
personne un homme ou une femme qui a
gagné le nobel deux fois (de phisique et de
chimie)"

COLECTIVIDADES

Community Chairs / Collectivités

YALTA	124
SEVILLA	146
CRETA	152
VIENA	158
MANILA	166
FRESNO	172
IOWA	180
CHIPRE	186
FLORIDA	192
VERONA	198
BAHÍA	204

Designer:
SIGFRIDO BILBAO

YALTA

COLECTIVIDADES

Community Chairs / Collectivités



YALTA

COLECTIVIDADES
Community Chairs / Collectivités















MEDIDAS / DIMENSIONS / DIMENSIONS



YALTA 1	YALTA 2	YALTA 3	YALTA 4	YALTA 5	YALTA 6	YALTA 7	YALTA 8
83	83	80	83	80/92	81	83	95
53	53	51	53	60	48	68	50
57	57	60	57	60	60	68	50
48	48	48	48	48/60	46	46	81
-	67	68 (opc)	-	60/80 (opc)	65 (opc)	-	101 (opc)
47	47	47	47	47	47	47	47
33	33	33	33	33	33	33	33



YALTA 9	YALTA 10	YALTA 11	YALTA 12	YALTA 13	YALTA 13R	YALTA 14	
114	95	114	85/110	81	79/91	83	Altura / Height / Haut
50	50	50	60	48	48	53	Anchura / Width / Large
50	50	50	60	60	60	57	Fondo / Depth / Fond
81	81	81	55/90	48	48/60	48	Altura asientos / Seat height / Hauteur siège
101 (opc)	-	-	75/100 (opc)	65 (opc)	60/80 (opc)	-	Altura brazos / Arms height / Hauteur accudors
47	47	47	47	47	47	47	Anchura Asiento / Seat width / Largeur d'assise
33	33	33	33	33	33	33	Anchura Respaldo / Backrest Width / Largeur dossier

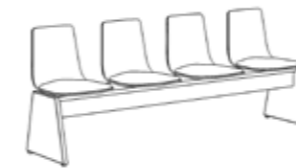

YALTA BANCADA 3/4/5 PUESTOS

83	Altura / Height / Haut
160/215/270	Anchura / Width / Large
56	Fondo / Depth / Fond
48	Altura asientos / Seat height / Hauteur siège
-	Altura brazos / Arms height / Hauteur accudors
47	Anchura Asiento / Seat width / Largeur d'assise
33	Anchura Respaldo / Backrest Width / Largeur dossier

ACABADOS / FINISHES / FINITIONS



4 PATAS METÁLICAS SIN BRAZOS

4 METAL LEGS WITHOUT ARMS / 4 PIEDS EN METAL SANS ACCOUDOIRS



YALTA 1



YALTA 15



YALTA 30

Apilable
Stackable
Empilage

4 PATAS METÁLICAS CON BRAZOS

METAL LEGS WITH ARMS / 4 PIEDS EN METAL AVEC ACCOUDOIRS



YALTA 2



YALTA 16



YALTA 31

Apilable
Stackable
Empilage

ESTRUCTURA DE PATÍN CROMADO / NEGRO

CHROME SLED STRUCTURE / STRUCTURE DE LUGE CHROMÉ



YALTA 3



YALTA 17



YALTA 32

Brazos opcionales
Optional Arms
Accoudoirs optionnelsApilable
Stackable
Empilage

4 PATAS DE MADERA

4 WOODEN LEGS / 4 PIEDS EN BOIS



YALTA 4



YALTA 18



YALTA 33

Los colores de este catálogo son orientativos,
la percepción de los mismos puede variar
respecto al original.The colours of this catalogue are reference,
the perception of the same can vary with
respect to the original one.Les couleurs figurant sur le catalogue
sont indicatifs ils peuvent varier para
rapport à l'original.

BASE GIRATORIA 5 RADIOS CON RUEDAS Y PISTÓN DE GAS

5-SPOKE SWIVEL BASE WITH WHEELS AND GAS-PISTON MECHANISM / CHAISE PIVOTANTE À 5 BRANCHES AVEC ROULETTES SUR VÉRIN À GAZ



YALTA 5



YALTA 19



YALTA 34

Brazos opcionales
Optional Arms
Accoudoirs optionnels

BASE PIRAMIDAL GIRATORIA 4 RADIOS DE POLIAMIDA

ROTATING PYRAMIDAL BASE 4 POLYAMIDE SPOKES / BASE PYRAMIDALE PIVOTANTE 4 RAYONS POLYAMIDE



YALTA 6



YALTA 20



YALTA 35

Brazos opcionales
Optional Arms
Accoudoirs optionnels

BASE PIRAMIDAL GIRATORIA 4 RADIOS DE POLIAMIDA. CON RUEDAS

ROTATING PYRAMIDAL BASE 4 POLYAMIDE SPOKES WITH WHEELS / BASE PYRAMIDALE PIVOTANTE 4 RAYONS POLYAMIDE.AVEC ROULETTES



YALTA 6R



YALTA 20R



YALTA 35R

Brazos opcionales
Optional Arms
Accoudoirs optionnels

BASE PIRAMIDAL GIRATORIA 4 RADIOS DE MADERA

PYRAMIDAL SWIVEL BASE 4 WOOD SPOKES / BASE PYRAMIDALE PIVOTANTE A 4 RAYONS EN BOIS



YALTA 7



YALTA 21



YALTA 36

TABURETE DE PATÍN CROMADO / NEGRO. RESPALDO BAJO

CHROME SLED STOOL. LOW BACK / TABOURET DE LUGE CHROMÉ. DOSSIER BAS



YALTA 8



YALTA 22



YALTA 37

Brazos opcionales
Optional Arms
Accoudoirs optionnels**TABURETE DE PATÍN CROMADO / NEGRO. RESPALDO ALTO**

CHROME SLED STOOL. HIGH BACK / TABOURET DE LUGE CHROMÉ. DOSSIER HAUT



YALTA 9



YALTA 23



YALTA 38

Brazos opcionales
Optional Arms
Accoudoirs optionnels**TABURETE DE 4 PATAS DE MADERA. RESPALDO BAJO**

4 WOODEN LEGS STOOL. LOW BACK / TABOURET DE 4 PIEDS EN BOIS. DOSSIER BAS



YALTA 10



YALTA 24



YALTA 39

TABURETE DE 4 PATAS DE MADERA. RESPALDO ALTO

4 WOODEN LEGS STOOL. HIGH BACK / TABOURET DE 4 PIEDS EN BOIS. DOSSIER HAUT



YALTA 11



YALTA 25



YALTA 40

TABURETE GIRATORIO 5 RADIOS CON RUEDAS, ARO REPOSAPIÉS Y PISTÓN DE GAS

ROTATING STOOL 5 SPOKES WITH WHEELS, FOOTREST RING AND GAS PISTON / TABOURET ROTATIF À 5 RAYONS AVEC ROULETTES, ANNEAU DE REPOSE-PIEDS ET PISTON A GAZ



YALTA 12



YALTA 26



YALTA 41

Brazos opcionales
Optional Arms
Accoudoirs optionnels**BASE PIRAMIDAL GIRATORIA METÁLICA DE 4 RADIOS CON TOPES**

METALLIC SWIVEL PYRAMIDAL BASE WITH 4 RADIOS WITH STOPS / BASE PYRAMIDALE PIVOTANTE MÉTALLIQUE AVEC 4 RADIOS AVEC BUTÉES



YALTA 13



YALTA 27



YALTA 42

Brazos opcionales
Optional Arms
Accoudoirs optionnels**BASE PIRAMIDAL GIRATORIA METÁLICA DE 5 RADIOS CON RUEDAS**

METALLIC SWIVEL PYRAMIDAL BASE WITH 5 RADIOS WITH CASTOR / BASE PYRAMIDALE PIVOTANTE MÉTALLIQUE AVEC 5 RADIOS AVEC ROUES



YALTA 13 R



YALTA 27 R



YALTA 42 R

Brazos opcionales
Optional Arms
Accoudoirs optionnels**4 PATAS METÁLICAS SIN BRAZOS COLOR NEGRO, CON PALA ABATIBLE**

4 METAL LEGS WITHOUT ARMS, WITH FOLDING TABLET / 4 PIEDS EN METAL SANS ACCOUDOIRS, AVEC TABLETTE PLIANTE



YALTA 14



YALTA 28



YALTA 43

BANCADA ESTRUCTURA MELAMINA

MELAMINE STRUCTURE BENCH/ BANC STRUCTURE MÉLAMINÉ

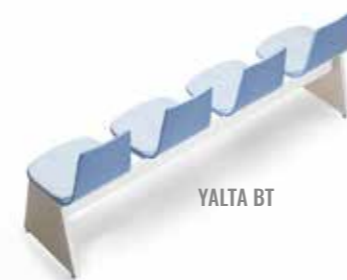

YALTA BT

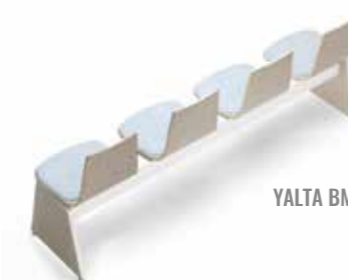

YALTA BM

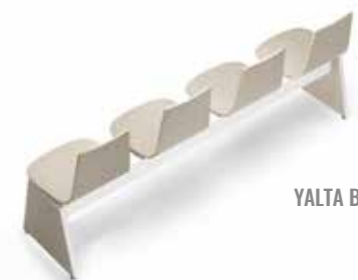

YALTA BMT

ESTRUCTURAS DE 4 PATAS METÁLICAS

4 METAL LEG STRUCTURES / STRUCTURE MÉTALLIQUE 4 PATAS

(color texturado / textured color / couleur texturée)



BLANCO / RAL 9003
White
Blanc

NEGRO / RAL 9005
Black
Noir

ALUMINIO / RAL 7045
Aluminium
Aluminium

BURDEOS / RAL 3005
Bordeaux
Bordeaux

AZUL / RAL 5010
Blue
Bleu

VERDE / RAL 6028
Green
Vert

PATAS DE MADERA

WOODEN LEGS / PIEDS EN BOIS



4 PATAS DE MADERA
4 WOODEN LEGS
4 PIEDS EN BOIS

BASE PIRAMIDAL GIRATORIA 4
RADIOS DE MADERA
PYRAMIDAL SWIVEL BASE 4
WOOD SPOKES
BASE PYRAMIDALE PIVOTANTE
A 4 RAYONS EN BOIS

TABURETE DE 4 PATAS DE MADERA
4 WOODEN LEGS STOOL
TABOURET DE 4 PIEDS EN BOIS

BARNIZ NATURAL
Natural Varnish
Verni Naturel

BARNIZ A ELEGIR
Other Varnish
Verni A Choisir

LACA RAL A ELEGIR
Other Lacquer
Laque A Choisir

BASES GIRATORIAS

ROTATING BASES / BASES ROTATIVES

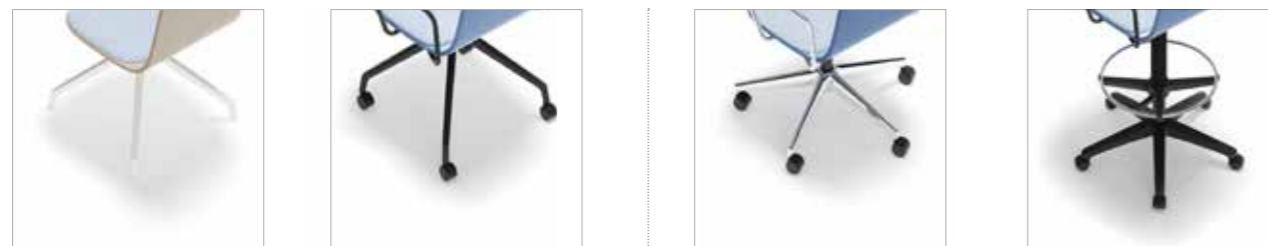

BASE PIRAMIDAL GIRATORIA 4
RADIOS DE POLIAMIDA
PYRAMIDAL SWIVEL BASE 4
POLYAMIDE SPOKES
BASE PYRAMIDALE PIVOTANTE
A 4 RAYONS POLYAMIDE

BASE PIRAMIDAL GIRATORIA 4 RADIOS
DE POLIAMIDA. CON RUEDAS.
ROTATING PYRAMIDAL BASE 4
POLYAMIDE SPOKES. WITH WHEELS
BASE PYRAMIDALE PIVOTANTE
4 RAYONS POLYAMIDE AVEC ROULETTES

BASE GIRATORIA 5 RADIOS CON
RUEDAS Y PISTÓN DE GAS
5-SPOKE SWIVEL BASE WITH WHEELS
AND GAS-PISTON MECHANISM
CHAISE PIVOTANTE À 5 BRANCHES
AVEC ROULETTES SUR VÉRIN À GAZ

TABURETE GIRATORIO 5 RADIOS CON RUEDAS,
ARO REPOSAPIÉS Y PISTÓN DE GAS
ROTATING STOOL 5 SPOKES WITH WHEELS, FOOTREST
RING AND GAS PISTON
ABOURET ROTATIF À 5 RAYONS AVEC ROULETTES,
ANNEAU DE REPOSE-PIEDS ET PISTON À GAZ



BLANCO
White
Blanc

NEGRO
Black
Noir



BLANCO
White
Blanc

NEGRO
Black
Noir

ALUMINIO PULIDO
Polished Aluminum
Aluminium Poli

BASES GIRATORIAS

ROTATING BASES / BASES ROTATIVES



BASE PIRAMIDAL GIRATORIA METÁLICA
DE 5 RADIOS CON RUEDAS
METALLIC SWIVEL PYRAMIDAL BASE
WITH 5 RADIOS WITH CASTOR

BASE PYRAMIDALE PIVOTANTE MÉTALLI-
QUE AVEC 5 RADIOS AVEC ROUES

BASE PIRAMIDAL GIRATORIA
METÁLICA DE 4 RADIOS CON TOPES
METALLIC SWIVEL PYRAMIDAL BASE WITH 4
RADIOS WITH STOPS

BASE PYRAMIDALE PIVOTANTE MÉTALLIQUE
AVEC 4 RADIOS AVEC BUTÉES

CROMO
Chrome
Chrome

JUEGO DE BRAZOS

ARMRESTS / ACCUDOIRS



EPOXI

CROMO



BLANCO
White
Blanc

NEGRO
Black
Noir

CROMO
Chrome
Chrome

CARCASAS TAPIZADAS

UPHOLSTERED SHELL / MONOCOQUE TAPISSÉE



CARCASA TOTALMENTE TAPIZADA
FULLY UPHOLSTERED SHELL
MONOCOQUE TOTALEMENT TAPISSÉE

CARCASA DE MADERA CON ASIENTO TAPIZADO
WOODEN SHELL WITH UPHOLSTERED SEAT
MONOCOQUE EN BOIS AVEC ASSISE TAPISSÉE

PALA EN POLIPROPILENO

POLYPROPYLENE TABLET / TABLETTE POLYPROPYLÈNE



NEGRO
Black
Noir

CARCASAS DE MADERA

WOODEN SHELL / MONOCOQUE EN BOIS

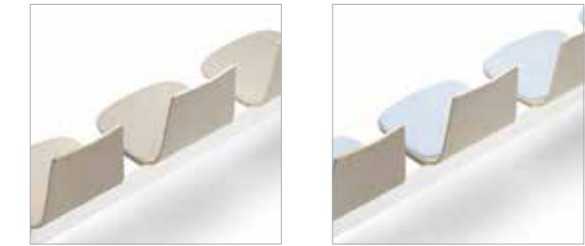

CARCASA DE MADERA
WOODEN SHELL
MONOCOQUE EN BOIS

CARCASA DE MADERA CON ASIENTO TAPIZADO
WOODEN SHELL WITH UPHOLSTERED SEAT
MONOCOQUE EN BOIS AVEC ASSISE TAPISSÉE



BARNIZ NATURAL
Natural Varnish
Verni Naturel

BARNIZ A ELEGIR
Other Varnish
Verni A Choisir

LACA RAL A ELEGIR
Other Lacquer
Laque A Choisir

Las sillas se pueden tapizar con cualquier tejido o piel de nuestro muestrario o con tejidos suministrados por el cliente.

Chairs can be upholstered in a any fabric or leather of our sample book or in COM.

Les chaises peuvent être tapissées avec n'importe quel tissu ou cuir de notre échantillonnage. Ou avec les tissus fournis par le client.

Designer:
SIGFRIDO BILBAO

SEVILLA

COLECTIVIDADES

Community Chairs / Collectivités



SEVILLA

COLECTIVIDADES
Community Chairs / Collectivités



SEVILLA
 SILLA DE COLECTIVIDADES

Silla de colectividades apilable de 4 patas, realizada en tubo de acero oval de 30x16 acabado en pintura epoxi de diferentes colores o cromado. Asiento y respaldo lacado, fabricado en madera contrachapada con espesor variable o bien tapizados sobre madera. Posibilidad de incorporar respaldo de malla, brazos en estructura, base giratoria con ruedas o base giratoria piramidal fija o con ruedas.

SEVILLA
 COMMUNITY CHAIR

Stackable community chair with 4 legs made in oval steel tube 30x16, epoxy paint finish in structure in different colors or chrome. Lacquered seat and back, made of plywood with varying thickness or upholstered on wood. Available with mesh back, arms in structure, writing tablet, swivel base with castors or swivel pyramidal base, fixed or with castors.

SEVILLA
 CHAISE DE COLLECTIVITÉS

Chaise de collectivités apilable de 4 pieds, réalisée dans un tube en acier ovale de 30 x 16 avec finition en peinture epoxi de différentes couleurs ou chromé. Assise et dossier laqué. Fabriqué en bois contre-plaqué avec une épaisseur variable ou bien des tapisseries sur la bois.. La possibilité d'incorporer un dossier de maille. Des bras dans une structure. Une base tournante avec roués ou une base pyramidale fixe ou avec roues.



SEVILLA	SEVILLA C/BRAZOS	SEVILLA MALLA	SEVILLA GIRATORIA	SEVILLA BASE PIRAMIDAL	
83	83	83	83/95	85	Altura / Height / Haut
53	57	53	53	53	Anchura / Width / Large
52	52	52	52	52	Fondo / Depth / Fond

ACABADOS MALLAS / MESH FINISHES / FINITIONS MAILLES

BLANCO	NEGRO	BURDEOS	AZUL	GRIS
White Blanc	Black Noir	Bordeaux Bordeaux	Blue Bleu	Grey Gris

METÁLICOS / METAL PARTS / MÉTALLIQUES

GRIS	BLANCO	NEGRO	CROMO
Grey Gris	White Blanc	Black Noir	Chrome Chrome

BASES GIRATORIAS / SWIVEL BASES / PIÈTEMENTS TOURNANT

GRIS	BLANCO	NEGRO	ALUMINIO PULIDO
Grey Gris	White Blanc	Black Noir	Polished Aluminum Aluminium Poli

MADERAS / WOODS / DES BOIS

LACA NEGRA	LACA BLANCA	LACA RAL A ELEGIR
Black Lacquer Laque Noir	White Lacquer Laque Blanc	Other Lacquer Laque A Choisir

OTROS ACABADOS / OTHER FINISHES / AUTRES FINITIONS

Acabados y tipologías de bases, ruedas, brazos y mecanismos:
Consultar tarifa.

Finishes, types of bases, castors, armrest and mechanisms.
Check price list.

Finitions et types de piètement, roués, accoudoirs et mécanismes.
Consulter le tarif.

TAPICERÍAS / UPHOLSTERY / TAPISSERIES

Las sillas se pueden tapizar con cualquier tejido o piel de nuestro muestrario (pág. 294) o con tejidos suministrados por el cliente.

Chairs can be upholstered in a any fabric or leather of our sample book (pág. 294) or in COM.

Les chaises peuvent être tapissées avec n'importe quel tissu ou cuir de notre échantillonnage (pág. 294) Ou avec les tissus fournis par le client.

Designer:
GREY DESIGN STUDIO

CRETA

COLECTIVIDADES

Community Chairs / Collectivités



CRETA

COLECTIVIDADES
Community Chairs / Collectivités



CRETA
SILLA DE COLECTIVIDADES

Silla de colectividades con estructura de 4 patas de madera de haya natural. Asiento y respaldo fabricado en monocarcasa plástica de polipropileno de diferentes colores. Posibilidad de incorporar base giratoria piramidal en poliamida de 4 radios con topes o ruedas y base giratoria piramidal metálica (acabado cromo) de 4 radios con topes o de 5 radios con ruedas.

CRETA
COMMUNITY CHAIR

Community chair with 4 legs made in beech wood. Polypropylene mono shell (seat & back) in different colors. Possibility of incorporating 4-castors polyamide pyramidal swivel base with stops or wheels and metallic pyramidal swivel base (chrome finish) with 4 castors with stops or 5 spokes with wheels.

CRETA
CHAISE DE COLLECTIVITES

Chaise de collectivités avec structure de 5 pieds de bois de hêtre naturelle. Assise et dossier fabriqué en monocarcasse plastique de polypropylène de différentes couleurs. Possibilité d'incorporer une base pivotante pyramidale en polyamide à 4 branches avec butées ou roulettes et une base pivotante pyramidale métallique (finition chromée) à 4 branches avec butées ou 5 branches avec roulettes.

**CRETA 1/2**80
57
52**CRETA 3/4**80
57
52**CRETA 5/6**80
57
52**CRETA 7/8**78/90
57
52
Altura / Height / Haut
Anchura / Width / Large
Fondo / Depth / Fond
ACABADOS PLÁSTICOS / PLASTIC FINISHES / FINITIONS PLASTIQUES

BLANCO

White
Blanc

NEGRO

Black
Noir

ROJO

Red
Rouge

AZUL

Blue
Bleu**BASES / BASES / PIÈTEMENTS**

BLANCO

White
Blanc

NEGRO

Black
Noir

MADERA HAYA

Beech
Bois Hêtre

CROMO

Chrome
Chrome**OTROS ACABADOS / OTHER FINISHES / AUTRES FINITIONS**

Acabados y tipologías de bases, ruedas, brazos y mecanismos:
Consultar tarifa.

Finishes, types of bases, castors, armrest and mechanisms.
Check price list.

Finitions et types de piètement, roués, accoudoirs et mécanismes.
Consulter le tarif.

TAPICERÍAS / UPHOLSTERY / TAPISSERIES

Las sillas se pueden tapizar con cualquier tejido o piel de nuestro muestrario (pág. 294) o con tejidos suministrados por el cliente.

Chairs can be upholstered in a any fabric or leather of our sample book (pag. 294) or in COM.

Les chaises peuvent être tapissées avec n'importe quel tissu ou cuir de notre échantillonnage (pag. 294) Ou avec les tissus fournis par le client.

Designer:
ALEGRE DESIGN

VIENA

COLECTIVIDADES
Community Chairs / Collectivités



VIENA

COLECTIVIDADES
Community Chairs / Collectivités

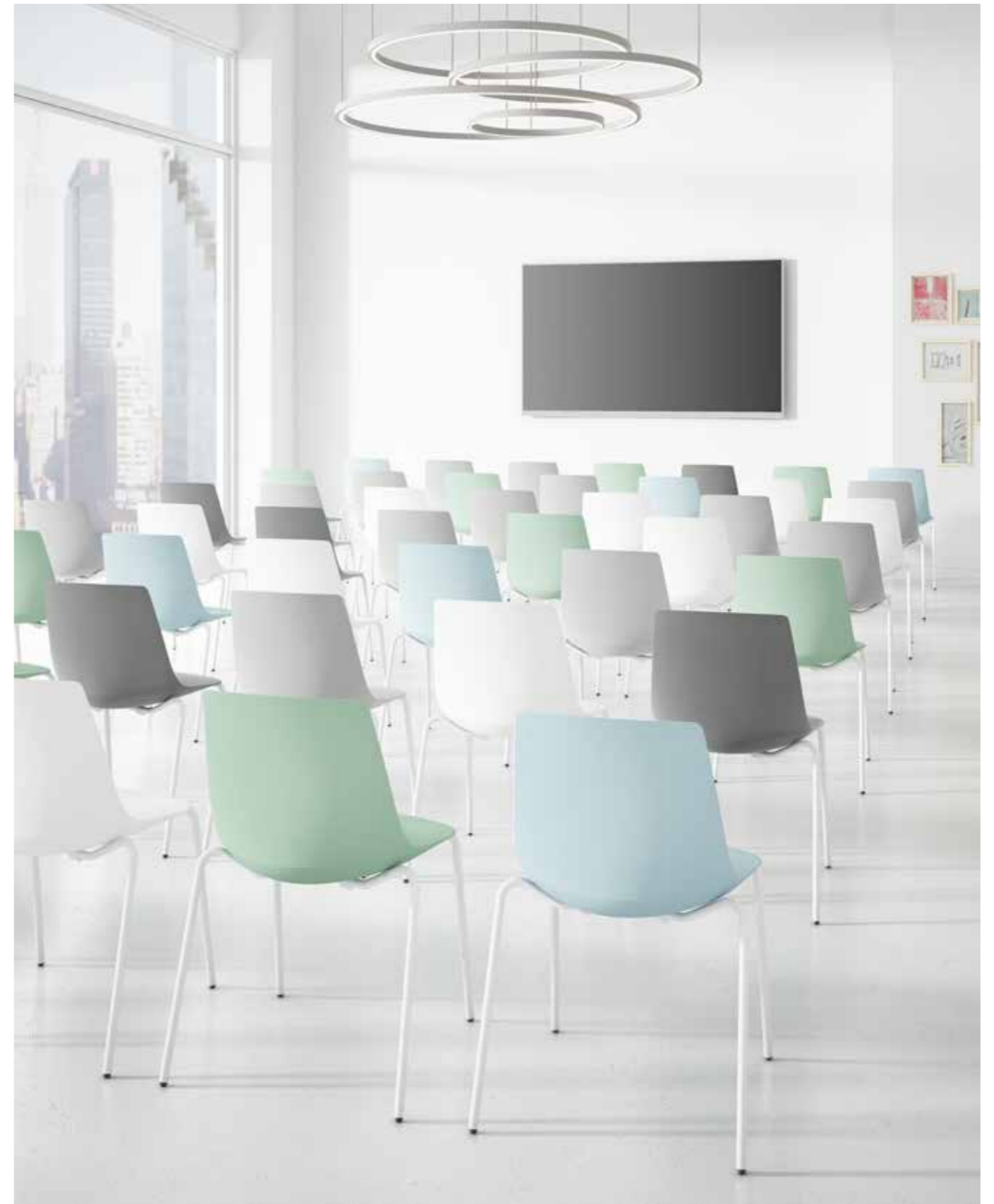

VIENA

COLECTIVIDADES
Community Chairs / Collectivités



VIENA
SILLA DE COLECTIVIDADES

Serie de colectividades con asiento y respaldo fabricado en monocarcasa de polipropileno reforzado con fibra de vidrio. Estructura de tubo de acero de 4 patas con tacos antideslizantes acabada en pintura epoxi. Brazos fijos opcionales fabricados en polipropileno reforzados con acero.

Silla apilable y transportable en carro portasillas. Posibilidad de incorporar asiento tapizado. Versión taburete fijo o giratoria con ruedas. Posibilidad de incorporar base giratoria piramidal en poliamida de 4 radios con topes o ruedas y base giratoria piramidal metálica (acabado cromo) de 4 radios con topes o de 5 radios con ruedas.

VIENA
COMMUNITY CHAIR

Community chair with seat and back made of mono shell polypropylene reinforced with fiberglass. Tubular steel 4 legs structure with stoppers painted in epoxy. Available with fixed arms made of polypropylene reinforced with steel. STACKABLE CHAIR and transportable in CHAIR CARRIER. Available with upholstered seat. Available fixed stool chair or swivel. Possibility of incorporating 4-castors polyamide pyramidal swivel base with stops or wheels and metallic pyramidal swivel base (chrome finish) with 4 castors with stops or 5 spokes with wheels.

VIENA
CHAISE DE COLLECTIVITES

Serie de collectivités avec assise et dossier, fabriqué en monocarcasse polypropylène renforcée en fibre de verre. Structure en tube d'acier de 4 pieds avec arrêts antidérapants fini en peinture époxy. Accoudoirs fixes optionnels fabriqués en polypropylène renforcée avec acier. Chaise apilable et transportable en chariot porta-sièges. Il y a possibilité d'incorporer le dossier de maille ou assise tapissée. Version tabouret fixe ou, tournant avec roues. Possibilité d'incorporer une base pivotante pyramidale en polyamide à 4 rayons avec butées ou roulettes et une base pivotante pyramidale en métal (finition chromée) à 4 rayons avec butées ou 5 rayons avec roulettes.



VIENA 1	VIENA 2	VIENA 3	VIENA 4	VIENA 5	VIENA T	VIENA G	VIENA P	Altura / Height / Haut
81	81	84	85	84/96	115	81/93	81	81
53	54	53	53	53	53	53	54	Anchura / Width / Large
52	52	52	52	52	52	52	52	Fondo / Depth / Fond

PLÁSTICOS Y BRAZOS / PLASTIC AND ARMREST / PLASTIQUES ET ACCOUDOIRS

GRIS	BLANCO	ANTRACITA	VERDE	AZUL	ZANAHORIA	AMARILLO
Grey Gris	White Blanc	Anthracite Anthracite	Green Vert	Blue Bleu	Carrot Carotte	Yellow Jaune

MÉTÁLICOS / METAL PARTS / MÉTALLIQUES

AZUL	GRIS	BLANCO	NEGRO
Blue Blue	Grey Gris	White Blanc	Black Noir

BASES GIRATORIAS / SWIVEL BASES / PIÈTEMENTS TOURNANT

GRIS	BLANCO	NEGRO	ALUMINIO PULIDO	CROMO
Grey Gris	White Blanc	Black Noir	Polished Aluminum Aluminium Poli	Chrome Chrome

OTROS ACABADOS / OTHER FINISHES / AUTRES FINITIONS

Acabados y tipologías de bases, ruedas, brazos y mecanismos: Consultar tarifa.

Finishes, types of bases, castors, armrest and mechanisms. Check price list.

Finitions et types de piétement, roues, accoudoirs et mécanismes. Consulter le tarif.

TAPICERÍAS / UPHOLSTERY / TAPISSERIES

Las sillas se pueden tapizar con cualquier tejido o piel de nuestro muestrario (pág. 294) o con tejidos suministrados por el cliente.

Chairs can be upholstered in a any fabric or leather of our sample book (pag. 294) or in COM.

Les chaises peuvent être tapissées avec n'importe quel tissu ou cuir de notre échantillonnage (pag. 294) Ou avec les tissus fournis par le client.

MANILA

COLECTIVIDADES

Community Chairs / Collectivités



MANILA

COLECTIVIDADES
Community Chairs / Collectivités



MANILA
SILLA DE COLECTIVIDADES

Silla de colectividades con brazos con estructura de 4 patas metálicas acabado cromo brillo. Asiento y respaldo fabricado en monocarcasa plástica de polipropileno de diferentes colores. Disponible con base fija de 4 patas de madera. Posibilidad de incorporar base giratoria piramidal en poliamida de 4 radios con topes o ruedas y base giratoria piramidal metálica (acabado cromo) de 4 radios con topes o de 5 radios con ruedas.

MANILA
COMMUNITY CHAIR

Stackable community chair with arms, bright chromed structure. Polypropylene mono shell (seat & back) in different colors. Available with fixed base with 4 wooden legs. Possibility of incorporating 4-castors polyamide pyramidal swivel base with stops or wheels and metallic pyramidal swivel base (chrome finish) with 4 castors with stops or 5 spokes with wheels.

MANILA
CHAISE DE COLLECTIVITES

Chaise de collectivités avec accoudoirs avec structure de 4 pieds métalliques fini chrome éclat. Assise et dossier fabriqué en monocarcasse plastique de polypropylène de différents couleurs. Avec la possibilité d'incorporer une base fixe à 4 pieds en bois, une base tournant pyramidale avec des arrêts ou roues.



MANILA 1/2

MANILA 3/4

MANILA 5/6

MANILA 7/8

MANILA 9/10

MANILA 1/2	MANILA 3/4	MANILA 5/6	MANILA 7/8	MANILA 9/10	
80	80	80	82	80/92	Altura / Height / Haut
59	59	59	59	59	Anchura / Width / Large
53	53	53	53	53	Fondo / Depth / Fond

ACABADOS PLÁSTICOS / PLASTIC FINISHES / FINITIONS PLASTIQUES

CREMA	CHOCOLATE	MOSTAZA	AZUL
Cream Crème	Chocolate Chocolat	Mustard Moutarde	Blue Bleu

BASES / BASES / PIÈTEMENTS

BLANCO	NEGRO	CROMO	MADERA
White Blanc	Black Noir	Chrome Chrome	Wood Bois

OTROS ACABADOS / OTHER FINISHES / AUTRES FINITIONS

Acabados y tipologías de bases, ruedas, brazos y mecanismos:
Consultar tarifa.

Finishes, types of bases, castors, armrest and mechanisms.
Check price list.

Finitions et types de piètement, roués, accoudoirs et mécanismes.
Consulter le tarif.

TAPICERÍAS / UPHOLSTERY / TAPISSERIES

Las sillas se pueden tapizar con cualquier tejido o piel de nuestro muestrario (pág. 294) o con tejidos suministrados por el cliente.

Chairs can be upholstered in a any fabric or leather of our sample book (pag. 294) or in COM.

Les chaises peuvent être tapissées avec n'importe quel tissu ou cuir de notre échantillonnage (pag. 294) Ou avec les tissus fournis par le client.

FRESNO

COLECTIVIDADES

Community Chairs / Collectivités

← COLECTIVIDADES



FRESNO

COLECTIVIDADES
Community Chairs / Collectivités



FRESNO

COLECTIVIDADES
Community Chairs / Collectivités



FRESNO
 SILLA DE COLECTIVIDADES

Serie de colectividadades con asiento y respaldo fabricado en polipropileno reforzado con fibra de vidrio. Estructura de tubo de acero de 4 patas con tacos antideslizantes acabada en pintura epoxi o cromo brillo. Brazos fijos opcionales fabricados en polipropileno reforzados con acero, con posibilidad de incorporar pala. Silla apilable y transportable en carro portasillas. Disponible unión entre sillas. Posibilidad de incorporar respaldo de malla y asiento tapizado. Vtaebrusiróente fijo o giratoria con ruedas (normal o taburete). Posibilidad de incorporar base giratoria piramidal en poliamida de 4 radios con topes o ruedas y base giratoria piramidal metálica (acabado cromo) de 4 radios con topes o de 5 radios con ruedas. Disponible con patín cromado.

FRESNO
 COMMUNITY CHAIR

Community chair with seat and back (micro-perforated) made of polypropylene reinforced with fiberglass. Tubular steel 4 legs structure with stoppers painted in epoxy or chromed. Available with fixed arms made of polypropylene reinforced with steel and writing tablet. Available connections between chairs. Stackable chair and transportable in carrying trolley. Available with upholstered seat. Available fixed stool chair or swivel (chair or stool). Possibility of incorporating 4-casters polyamide pyramidal swivel base with stops or wheels and metallic pyramidal swivel base (chrome finish) with 4 castors with stops or 5 spokes with wheels. Available with chrome sled.

FRESNO
 CHAISE DE COLLECTIVITÉS

Chaise de collectivités avec assise et dossier (micro-perforé) en polypropylène renforcé de fibre de verre. Structure tubulaire en acier à 4 pieds avec butées antideslizantes peintes en époxy ou chromées. Disponible avec bras fixes en polypropylène renforcé d'acier et tablette écriteiro. Connexions disponibles entre les chaises. Chaise empilable et transportable en chariot de transport. Disponible avec assise rembourrée. Disponible chaise tabouret fixe ou pivotant (fauteuil ou tabouret). Possibilité d'incorporer une base pivotante pyramidale en polyamide à 4 roulettes avec butées ou roulettes et une base pivotante pyramidale métallique (finition chromée) à 4 roulettes avec butées ou 5 rayons avec roulettes. Disponible avec traineau chromé.



FRESNO 1	FRESNO 1 CON BRAZOS	FRESNO 1 RESPALDO MALLA	FRESNO 6	FRESNO 7	FRESNO 8/9	FRESNO G	FRESNO TF	FRESNO TG	FRESNO P	
82	82	82	87	86/98	85	80/92	118	85/110	86	Altura / Height / Haut
50	58	50	50	50	50	50	52	50	50	Anchura / Width / Large
56	56	56	56	56	56	56	52	56	54	Fondo / Depth / Fond

ACABADOS MALLAS / MESH FINISHES / FINITIONS MAILLES

BLANCO	NEGRO	BURDEOS	AZUL	VERDE	MELOCOTÓN	VISÓN	GRIS
White Blanc	Black Noir	Bordeaux Bordeaux	Blue Bleu	Green Vert	Peach Pêche	Mink Vison	Grey Gris

METÁLICOS / METAL PARTS / MÉTALLIQUES

CROMO	GRIS	BLANCO	NEGRO
Chrome Chrome	Grey Gris	White Blanc	Black Noir

PLÁSTICOS Y BRAZOS / PLASTIC AND ARMREST / PLASTIQUES ET ACCOUDOIRS

GRIS	BLANCO	NEGRO	VERDE	ZANAHORIA	AMARILLO	AZUL
Grey Gris	White Blanc	Black Noir	Green Vert	Carrot Carotte	Yellow Jaune	Blue Bleu

BASES GIRATORIAS / SWIVEL BASES / PIÈTEMENTS TOURNANT

GRIS	BLANCO	CROMO	NEGRO	ALUMINIO PULIDO
Grey Gris	White Blanc	Chrome Chrome	Black Noir	Polished Aluminum Aluminium Poli

OTROS ACABADOS / OTHER FINISHES / AUTRES FINITIONS

Acabados y tipologías de bases, ruedas, brazos y mecanismos: Consultar tarifa.	Finishes, types of bases, castors, armrest and mechanisms. Check price list.	Finitions et types de piétement, roués, accoudoirs et mécanismes. Consulter le tarif.
--	--	---

TAPICERÍAS / UPHOLSTERY / TAPISSERIES

Las sillas se pueden tapizar con cualquier tejido o piel de nuestro muestrario (pág. 294) o con tejidos suministrados por el cliente.

Chairs can be upholstered in a any fabric or leather of our sample book (pag. 294) or in COM.

Les chaises peuvent être tapissées avec n'importe quel tissu ou cuir de notre échantillonnage (pag. 294) Ou avec les tissus fournis par le client.

IOWA

COLECTIVIDADES

Community Chairs / Collectivités





IOWA
SILLA DE COLECTIVIDADES

Serie de colectividades con asiento y respaldo (micro perforado) fabricado en polipropileno reforzado con fibra de vidrio. Estructura de tubo de acero de 4 patas con tacos antideslizantes acabada en pintura epoxi o cromo brillo. Brazos fijos opcionales fabricados en polipropileno reforzados con acero, con posibilidad de incorporar pala. Silla apilable y transportable en carro portasillas. Disponible unión entre sillas. Posibilidad de incorporar asiento tapizado. Versión taburete fijo o giratoria con ruedas (normal o taburete). Posibilidad de incorporar base giratoria piramidal en poliamida de 4 radios con topes o ruedas y base giratoria piramidal metálica (acabado cromo) de 4 radios con topes o de 5 radios con ruedas. Disponible con patín cromado.

IOWA
COMMUNITY CHAIR

Community chair with seat and back (micro-perforated) made of polypropylene reinforced with fiberglass. Tubular steel 4 legs structure with stoppers painted in epoxy or chromed. Available with fixed arms made of polypropylene reinforced with steel and writing tablet. Available connections between chairs. Stackable chair and transportable in carrying trolley. Available with upholstered seat. Available fixed stool chair or swivel (chair or stool), or swivel pyramidal base, fixed or with castors. Possibility of incorporating 4-castors polyamide swivel base with stops or wheels and metallic pyramidal swivel base (chrome finish) with 4 castors with stops or 5 spokes with wheels. Available with chrome sled.

IOWA
CHAISE DE COLLECTIVITÉS

Serie de collectivités avec assise et dossier (micro-perforé), fabriqué en polypropylène renforcée en fibre de verre. Structure en tube d'acier de 4 pieds avec arrêts antidérapants fini en peinture epoxy ou chromé éclat. Accoudoirs fixes optionnels fabriqués en polypropylène renforcée avec acier, avec la possibilité d'incorporer une pelle pour écriture. Chaise apilable et transportable en chariot porta-sièges. Disponible une pièce de liaison pour les sièges. Il y a possibilité d'incorporer assise tapissée. Version tabouret fixe, ou tournant avec roues (normal ou tabouret). Possibilité d'incorporer une base pivotante pyramidale en polyamide à 4 roulettes avec butées ou roulettes et une base pivotante pyramidale métallique (finition chromée) à 4 roulettes avec butées ou 5 rayons avec roulettes. Disponible avec traîneau chromé.



IOWA 1	IOWA 1 CON BRAZOS	IOWA 6	IOWA 7	IOWA 8/9	IOWA G	IOWA TF	IOWA TG	IOWA P	
82	82	87	86/98	85	80/92	118	85/110	86	Altura / Height / Haut
56	58	50	50	50	50	52	50	50	Anchura / Width / Large
	56	56	56	56	56	52	56	54	Fondo / Depth / Fond

METÁLICOS / METAL PARTS / MÉTALLIQUES

CROMO	GRIS	BLANCO	NEGRO
Chrome Chrome	Grey Gris	White Blanc	Black Noir

PLÁSTICOS Y BRAZOS / PLASTIC AND ARMREST / PLASTIQUES ET ACCOUDOIRS

GRIS	BLANCO	NEGRO	VERDE	ZANAHORIA	AMARILLO	AZUL
Grey Gris	White Blanc	Black Noir	Green Vert	Carrot Carotte	Yellow Jaune	Blue Bleu

BASES GIRATORIAS / SWIVEL BASES / PIÈTEMENTS TOURNANT

GRIS	BLANCO	CROMO	NEGRO	ALUMINIO PULIDO
Grey Gris	White Blanc	Chrome Chrome	Black Noir	Polished Aluminum Aluminium Poli

OTROS ACABADOS / OTHER FINISHES / AUTRES FINITIONS

Acabados y tipologías de bases, ruedas, brazos y mecanismos:
Consultar tarifa.

Finishes, types of bases, castors, armrest and mechanisms.
Check price list.

Finitions et types de piètement, roués, accoudoirs et mécanismes.
Consulter le tarif.

TAPICERÍAS / UPHOLSTERY / TAPISSERIES

Las sillas se pueden tapizar con cualquier tejido o piel de nuestro muestrario (pág. 294) o con tejidos suministrados por el cliente.

Chairs can be upholstered in a any fabric or leather of our sample book (pag. 294) or in COM.

Les chaises peuvent être tapissées avec n'importe quel tissu ou cuir de notre échantillonnage (pag. 294) Ou avec les tissus fournis par le client.

Designer:
ANDREAS OSTWALD

CHIPRE

COLECTIVIDADES

Community Chairs / Collectivités



CHIPRE

COLECTIVIDADES
Community Chairs / Collectivités





CHIPRE
SILLA DE COLECTIVIDADES

Silla de colectividades apilable con estructura de tubo de acero de 4 patas con tacos antideslizantes acabada en pintura epoxi o cromo brillo. Asiento y respaldo fabricado en monocarcasa plástica de polipropileno de diferentes colores. Posibilidad de taburete fijo. Versión giratoria con ruedas y posibilidad de asiento tapizado.

CHIPRE
COMMUNITY CHAIR

Stackable community chair with tubular steel 4 legs structure with stoppers painted in epoxy or chromed. Polypropylene mono shell (seat & back) in different colors. Available swivel chair with casters & with upholstered seat.

CHIPRE
CHAISE DE COLLECTIVITES

Chaise de collectivités apilable avec structure de tube d'acier avec 4 pieds avec arrêts antidérapants. Fini en peinture epoxy au chrome éclat. Assise et dossier fabriqué en monocarcasse plastique de polypropylene de différentes couleurs. Avec la possibilité d'incorporer assise tapissé et tournant avec roues.



CHIPRE

80
48
52

CHIPRE T

113
48
55

CHIPRE G

80/92
48
52

Altura / Height / Haut
Anchura / Width / Large
Fondo / Depth / Fond

ACABADOS PLÁSTICOS / PLASTIC FINISHES / FINITIONS PLASTIQUES

BLANCO



White
Blanc

NEGRO



Black
Noir

MARSALA



Marsala
Marsala

CURRY



Curry
Curry

METÁLICOS / METAL PARTS / MÉTALLIQUES

CROMO



Chrome
Chrome

BLANCO



White
Blanc

BASES / BASES / PIÈTEMENTS

BLANCO



White
Blanc

CROMO



Chrome
Chrome

BASES GIRATORIAS / SWIVEL BASES / PIÈTEMENTS TOURNANT

BLANCO



White
Blanc

NEGRO



Black
Noir

ALUMINIO PULIDO



Polished Aluminum
Aluminium Poli

TAPICERÍAS / UPHOLSTERY / TAPISSERIES

Las sillas se pueden tapizar con cualquier tejido o piel de nuestro muestrario (pág. 294) o con tejidos suministrados por el cliente.

Chairs can be upholstered in a any fabric or leather of our sample book (pag. 294) or in COM.

Les chaises peuvent être tapissées avec n'importe quel tissu ou cuir de notre échantillonnage (pag. 294) Ou avec les tissus fournis par le client.

Designer:

JEREMIAH FERRARESE & PAOLO SCAGNELLATO

FLORIDA

COLECTIVIDADES

Community Chairs / Collectivités



FLORIDA

COLECTIVIDADES
Community Chairs / Collectivités



FLORIDA
 SILLA DE COLECTIVIDADES

Serie de colectividades con asiento y respaldo tapizado. El respaldo incorpora un marco perimetral fabricado en poliamida. Existe la posibilidad de incorporar malla en el respaldo de diferentes colores. Estructura de tubo de acero de 4 patas acabada en pintura epoxi o cromo brillo. Opcionalmente incorpora estructura de patín en acabado cromo brillo. Brazos fijos fabricados en poliamida, con posibilidad de incorporar pala. Silla apilable (incluso con pala) y transportable en carro portasilas. Disponible unión entre sillas.

FLORIDA
 COMMUNITY CHAIR

Community chair with upholstered seat and back, the back is made of polyamide perimeter structure. Available with mesh back in different colors. Tubular steel legs painted in epoxy or chromed. Optionally, it incorporates a sled structure in a bright chrome finish. Available with polyamide fixed arms and writing tablet. Stackable even with tablet and transportable with a trolley. Available connections for chairs..

FLORIDA
 CHAISE DE COLLECTIVITÉS

Serie de collectivités avec assise et dossier tapissé. Le dossier incorpore un cadre perimetral fabriqué comme polyamide. Il y a la possibilité d'incorporer une maille dans le dossier de différents couleurs. Structure de tube d'acier de 4 pieds fini en peinture d'époxy ou chrome éclat. En option, il intègre une structure de traîneau dans une finition chromée brillante. Accoudoirs fixes fabriqués en polyamide avec la possibilité d'incorporer une tablette. Chaise apilable (même avec tablette) et transportable avec chariot porta-sièges. Disponible avec pièce de liaison entre chaises.

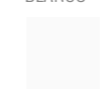
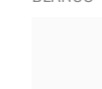
**FLORIDA 1**82
52
50**FLORIDA 2**82
52
50**FLORIDA CON BRAZOS**82
59
50**FLORIDA P**86
52
54
Altura / Height / Haut
Anchura / Width / Large
Fondo / Depth / Fond
ACABADOS MALLAS / MESH FINISHES / FINITIONS MAILLES**BLANCO**White
Blanc**NEGRO**Black
Noir**BURDEOS**Bordeaux
Bordeaux**AZUL**Blue
Bleu**VERDE**Green
Vert**MELOCOTÓN**Peach
Pêche**VISÓN**Mink
Vison**GRIS**Grey
Gris**METÁLICOS / METAL PARTS / MÉTALLIQUES****CROMO**Chrome
Chrome**BLANCO**White
Blanc**NEGRO**Black
Noir**PLÁSTICOS Y BRAZOS / PLASTIC AND ARMREST / PLASTIQUES ET ACCOUDOIRS****BLANCO**White
Blanc**NEGRO**Black
Noir**OTROS ACABADOS / OTHER FINISHES / AUTRES FINITIONS**

Acabados y tipologías de bases, ruedas, brazos y mecanismos:
Consultar tarifa.

Finishes, types of bases, castors, armrest and mechanisms.
Check price list.

Finitions et types de piétement, roués, accoudoirs et mécanismes.
Consulter le tarif.

TAPICERÍAS / UPHOLSTERY / TAPISSERIES

Las sillas se pueden tapizar con cualquier tejido o piel de nuestro muestrario (pág. 294) o con tejidos suministrados por el cliente.

Chairs can be upholstered in a any fabric or leather of our sample book (pag. 294) or in COM.

Les chaises peuvent être tapissées avec n'importe quel tissu ou cuir de notre échantillonnage (pag. 294) Ou avec les tissus fournis par le client.

VERONA

COLECTIVIDADES

Community Chairs / Collectivités



VERONA

COLECTIVIDADES
Community Chairs / Collectivités



VERONA
SILLA DE COLECTIVIDADES

Serie de colectividades con asiento y respaldo (perforado) fabricado en polipropileno reforzado con fibra de vidrio. Estructura de tubo de acero de 4 patas con tacos antideslizantes acabada en pintura epoxi o cromo brillo. Brazos fijos opcionales fabricados en polipropileno. Posibilidad de incorporar pala.

Silla apilable y transportable en carro portasilas. Disponible unión entre sillas. Posibilidad de incorporar respaldo de malla y asiento y respaldo tapizado.

Versión taburete fijo o giratoria con ruedas (normal o taburete). Posibilidad de incorporar base giratoria piramidal en poliamida de 4 radios con topes o ruedas y base giratoria piramidal metálica (acabado cromo) de 4 radios con topes o de 5 radios con ruedas. Disponible con patín cromado.

VERONA
COMMUNITY CHAIR

Community chair with polypropylene seat and backrest (perforated) reinforced with fiberglass. Tubular steel legs painted in epoxy or chromed. Available with polyamide fixed arms and writing tablet. Stackable and transportable with a trolley. Available connections for chairs. Available with seat and back upholstered or mesh back.

Available fixed stool chair or swivel (chair or stool). Possibility of incorporating 4-casters polyamide pyramidal swivel base with stops or wheels and metallic pyramidal swivel base. (chrome finish) with 4 castors with stops or 5 spokes with wheels. Available with chrome sled.

VERONA
CHAISE DE COLECTIVITÉS

Serie de colectivités avec assise et dossier perforé. Fabriqué en polypropylène renforcée avec fibre de verre. Structure de tube d'acier de 4 pieds avec arrêts antidérapants fini en peinture epoxy au chrome éclat. Accoudoirs fixes optionnels fabriqués en polypropylène. Il y a possibilité d'incorporer une tablette. Chaise apilable et transportable en chariot portasièges. Disponible piéde de liaison entre chaises. Possibilité d'incorporer dossier de maille et assise et dossier tapissé. Version tabouret fixe ou tournant avec roués (normal ou tabouret). Possibilité d'incorporer une base pivotante pyramidale en polyamide à 4 roulettes avec butées ou roulettes et une base pivotante pyramidale métallique (finition chromée) à 4 roulettes avec butées ou 5 rayons avec roulettes. Disponible avec traîneau chromé. Disponible avec patin chromé.



VERONA 1	VERONA 1 CON BRAZOS	VERONA 1 RESPALDO MALLA	VERONA 6	VERONA 7	VERONA 8/9	VERONA G	VERONA TF	VERONA TG	VERONA P	
82	82	82	85	84/96	85	80/92	118	85/110	86	Altura / Height / Haut
51	59	51	51	51	51	51	53	51	52	Anchura / Width / Large
53	53	53	53	53	53	53	53	53	54	Fondo / Depth / Fond

ACABADOS MALLAS / MESH FINISHES / FINITIONS MAILLES

BLANCO	NEGRO	BURDEOS	VERDE	MELOCOTÓN	VISÓN	GRIS
White Blanc	Black Noir	Bordeaux Bordeaux	Green Vert	Peach Pêche	Mink Vison	Grey Gris

METÁLICOS / METAL PARTS / MÉTALLIQUES

CROMO	GRIS	BLANCO	NEGRO
Chrome Chrome	Grey Gris	White Blanc	Black Noir

BASES GIRATORIAS / SWIVEL BASES / PIÈTEMENTS TOURNANT

GRIS	BLANCO	NEGRO	CROMO	ALUMINIO PULIDO
Grey Gris	White Blanc	Black Noir	Chrome Chrome	Polished Aluminum Aluminium Poli

PLÁSTICOS Y BRAZOS / PLASTIC AND ARMREST / PLASTIQUES ET ACCOUDOIRS

NEGRO	BURDEOS	GRIS	VERDE	ZANAHORIA	AMARILLO	AZUL
Black Noir	Bordeaux Bordeaux	Grey Gris	Green Vert	Carrot Carotte	Yellow Jaune	Blue Bleu

OTROS ACABADOS / OTHER FINISHES / AUTRES FINITIONS

Acabados y tipologías de bases, ruedas, brazos y mecanismos: Consultar tarifa. Finishes, types of bases, castors, armrest and mechanisms. Check price list. Finitions et types de piètement, roués, accoudoirs et mécanismes. Consulter le tarif.

TAPICERÍAS / UPHOLSTERY / TAPISSERIES

Las sillas se pueden tapizar con cualquier tejido o piel de nuestro muestrario (pág. 294) o con tejidos suministrados por el cliente.

Chairs can be upholstered in a any fabric or leather of our sample book (pag. 294) or in COM.

Les chaises peuvent être tapissées avec n'importe quel tissu ou cuir de notre échantillonnage (pag. 294) Ou avec les tissus fournis par le client.

BAHÍA

COLECTIVIDADES

Community Chairs / Collectivités



BAHÍA
SILLA DE COLECTIVIDADES

Silla de colectividades monocarcasa fabricada en *po-lipropileno* de varios colores.

Estructura fija de 4 patas en acero cromado de diámetro 20x2mm. con tacos antideslizantes.

BAHÍA
COMMUNITY CHAIR

Community Chair made of a mono polypropylene shell in different colors.

Fixed 4 legs structure made of chromed steel 20 x 2 mm. Includes non-slip stoppers.

BAHÍA
CHAISE DE COLLECTIVITÉS

Siège de collectivités. Monocarcasse fabriqué en *polypropylène* de divers couleurs.





Structure fixe d 4 pieds d'acier chrome. Diamètre de 20 x 2 mm avec arrêts antidérapants.



BAHÍA
81
50
60

Altura / Height / Haut
Anchura / Width / Large
Fondo / Depth / Fond

ACABADOS PLÁSTICOS / PLASTIC FINISHES / FINITIONS PLASTIQUES

NEGRO	BLANCO	AZUL	PISTACHO	ROJO
				
White Blanc	Black Noir	Blue Bleu	Pistachio Pistache	Red Rouge

METÁLICOS / METAL PARTS / MÉTALLIQUES

CROMO

Chrome
Chrome



MENOS ES MÁS

LUDWIG MIES VAN DER ROHE

"Mies van der Rohe, junto con Walter Gropius, Le Corbusier y Frank Lloyd Wright, está considerado como uno de los principales arquitectos del siglo XX."

"LESS IS MORE"

Ludwig Mies Van Der Rohe

"Mies van der Rohe, along with Walter Gropius, Le Corbusier and Frank Lloyd Wright, He is considered one of the leading architects of the 20th century."

"MOINS IL EST PLUS"

Ludwig Mies Van Der Rohe

"Mies van der Rohe, avec Walter Gropius, Le Corbusier et Frank Lloyd Wright, il est considéré comme l'un des architectes principaux du XXe siècle."

CONTRACT & SOFT SEATING

BASEL	210
GLASGOW	218
TRÍPOLI	224
DAKAR	230
NIGER	236
SEVILLA	242
VENECIA	248
MALTA	254
LORCA	258
ALBERTA	262
MEMPHIS	268
ANGOLA	274
VANCOUVER	278

Designer:
SIGFRIDO BILBAO

BASEL

**CONTRACT
& SOFT SEATING**



BASEL

CONTRACT
& SOFT SEATING

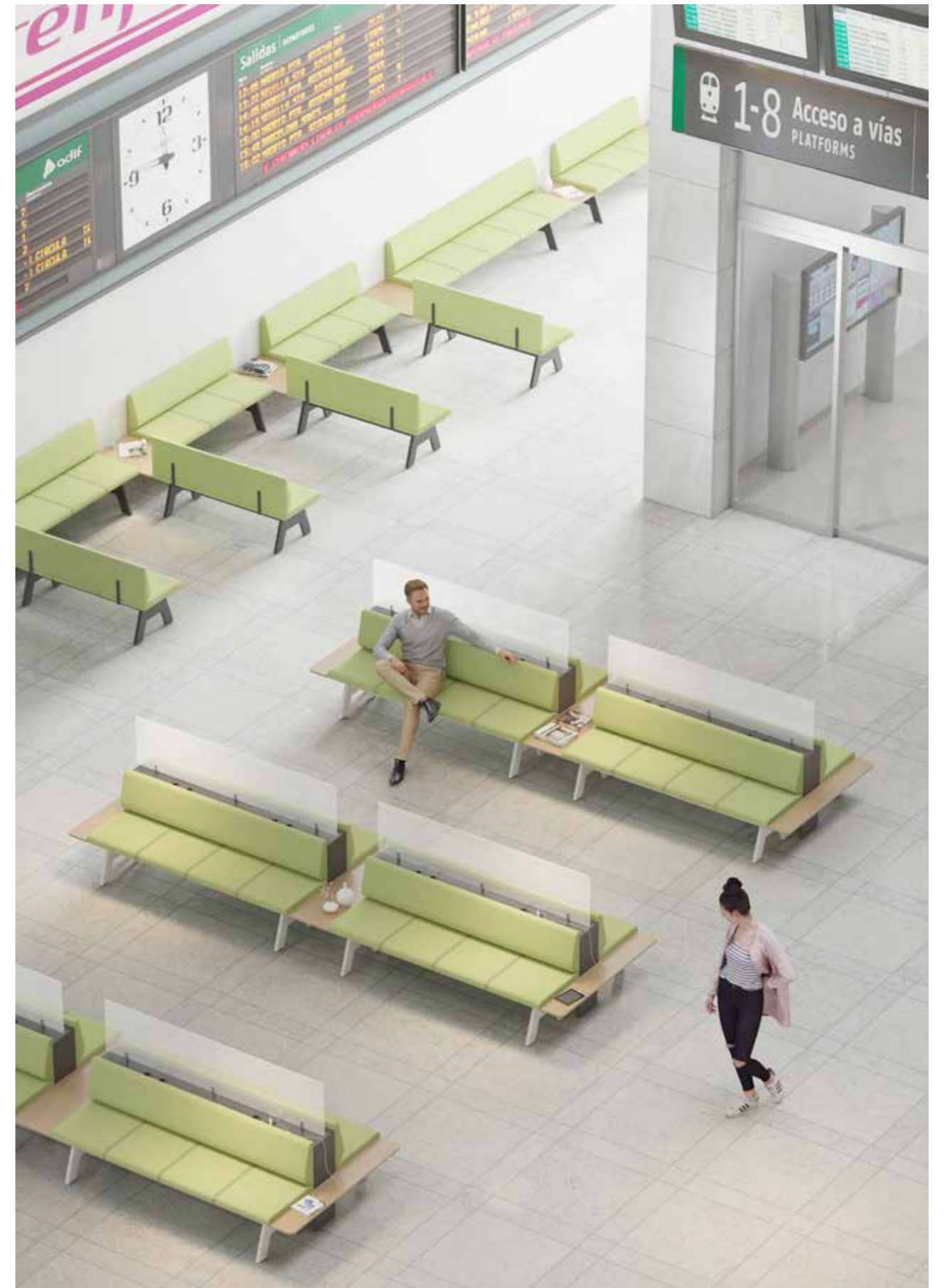



BASEL
 CONTRACT & SOFT SEATING

Banco de espera de 2, 3, 4 ó 5 plazas. Patas de DM de 30mm, lacadas en blanco o negro unidas mediante dos faldones de melamina a juego con las patas. Asiento tapizado sobre tablero contrachapado de abedul de 21mm, de espesor y espuma de 50mm, y 35 Kg/m³ de densidad. Posibilidad de respaldo tapizado sobre tablero contrachapado de abedul de 21mm, de espesor y espuma de 45 Kg/m³ de densidad. Respaldo unido al asiento mediante pletina de acero de 8mm, de espesor acabado en pintura epoxy blanca o negra. Uniones y accesorios fabricados en melamina de 25mm, de espesor.

BASEL
 CONTRACT & SOFT SEATING

2, 3, 4 or 5 seater waiting bench. 30mm MDF legs lacquered in white or black joined by two melamine beams to match the legs. Seat upholstered on 21mm thick birch plywood board and 50mm foam and 35 Kg / m³ density. Possibility of upholstered backrest on 21mm thick birch plywood board and 45 Kg / m³ density. Backrest attached to the seat by 8mm thick steel plate finished in white or black epoxy paint. Joints and accessories made of 25mm thick melamine.

BASEL
 CONTRACT & SOFT SEATING

Banc d'attente 2, 3, 4 ou 5 places. Pieds en MDF de 30 mm laqués en blanc ou noir réunis par deux poutres en mélamine assorties aux pieds. Assise tapissée sur planche de contreplaqué bouleau épaisseur 21mm et mousse 50mm et densité 35 Kg/m³. Possibilité de dossier capitonné sur panneau de contreplaqué bouleau épaisseur 21mm et mousse densité 45 Kg/m³. Dossier fixé à l'assise par plaque d'acier de 8 mm d'épaisseur finition peinture époxy blanche ou noire. Joints et accessoires en mélaminé épaisseur 25 mm.

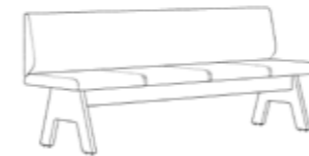

BASEL 1
 80
 100 / 150 / 200 / 250
 56



BASEL 2
 45
 100 / 150 / 200 / 250
 56

Altura / Height / Haut
Anchura / Width / Large
Fondo / Depth / Fond

ACABADOS PATAS (FALDONES MELAMINA A JUEGO)

FINISHES LEGS (MATCHING MELAMINE BEAMS) / FINITIONS JAMBES (ASSORTIES AUX JUPES EN MÉLAMINE)

LACA BLANCA



White
Blanc

LACA NEGRA



Black
Noir

LACA RAL A ELEGIR



Other Lacquer
Laque Ral A Choisir

OTROS ACABADOS / OTHER FINISHES / AUTRES FINITIONS

Elementos metálicos: blanco o negro
 Elementos electrificación: Mirar Tarifa Ismobel.
 Metacrilatos: Transparente o traslúcido.

Metallic elements: white or black
 Electrification elements: See Ismobel price list.
 Metacrylate rate: Transparent or translucent.

MESAS, ÁNGULOS Y UNIONES

FINISHES TABLES, ANGLES AND JOINTS
 FINITIONS TABLES, ANGLES ET JOINTS

MELAMINA



Melamine
Melamine

Éléments Métalliques : Blanc Ou Noir
 Éléments D'électrification : Consultez le tarif Ismobel.
 Méthacrylates : Transparent ou translucide.

TAPICERÍAS / UPHOLSTERY / TAPISSERIES

Las sillas se pueden tapizar con cualquier tejido o piel de nuestro muestrario (pág. 294) o con tejidos suministrados por el cliente.

Chairs can be upholstered in a any fabric or leather of our sample book (pág. 294) or in COM.

Les chaises peuvent être tapissées avec n'importe quel tissu ou cuir de notre échantillonnage (pág. 278) Ou avec les tissus fournis par le client.

Designer:
SIGFRIDO BILBAO

GLASGOW

CONTRACT
& SOFT SEATING



GLASGOW

CONTRACT
& SOFT SEATING

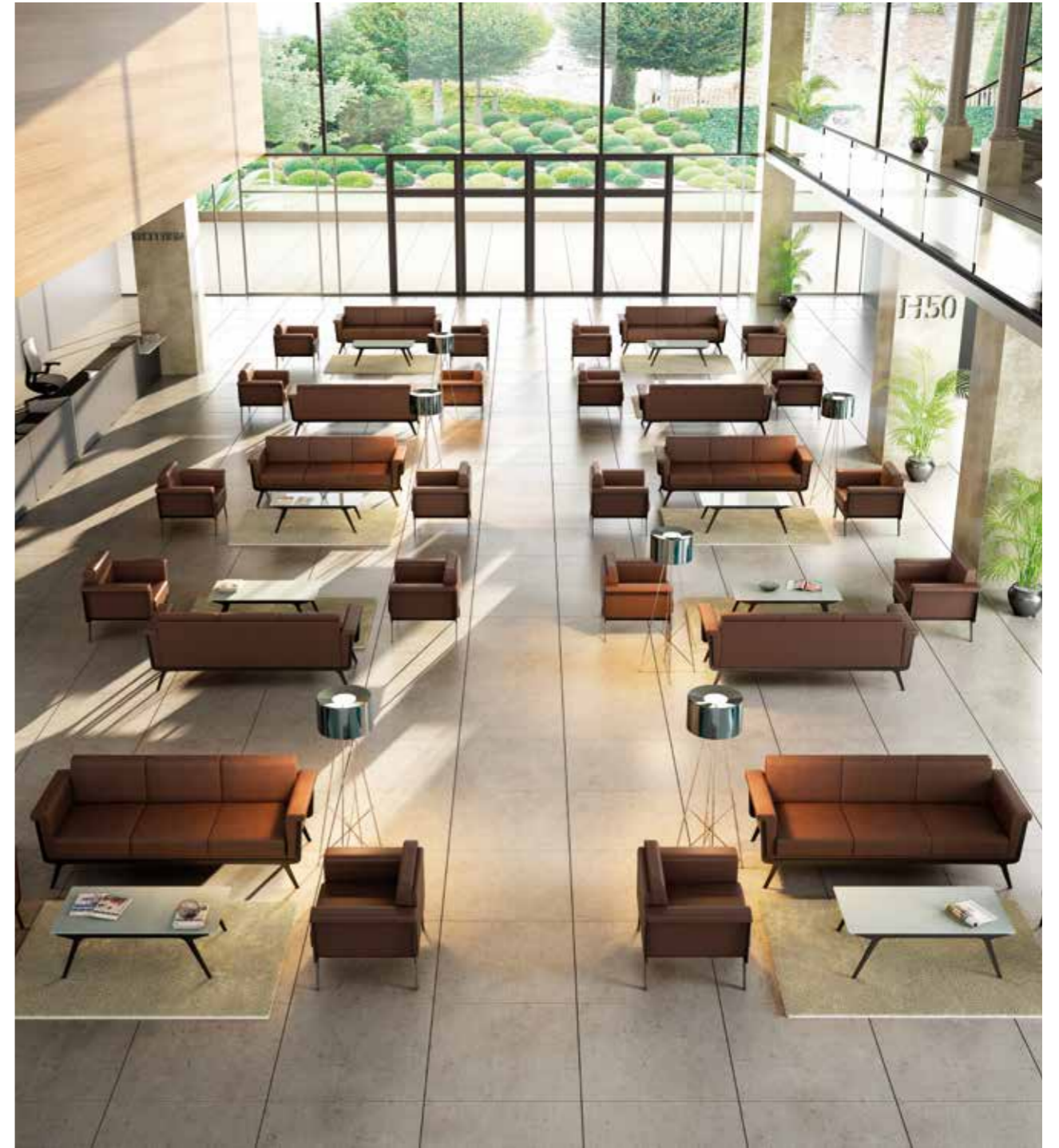

GLASGOW
 CONTRACT & SOFT SEATING

Sofá de recepción de 1 ó 3 plazas. Estructura metálica sobre la que se apoya la base y el respaldo de madera completamente tapizado. Brazos y cojines tapizados sobre espuma de poliuretano indeformable de alta resistencia. Existe la posibilidad de incorporar mesas de centro en madera o en cristal.

GLASGOW
 CONTRACT & SOFT SEATING

Sofa for reception, 1 or 3 seaters. Metallic structure which supports the base and the wood back fully upholstered. Arms and cushions upholstered in polyurethane foam of high strength. Available coffee tables in wood or glass.

GLASGOW
 CONTRACT & SOFT SEATING

Canapé de réception de 1 ou 3 places. Structure métallique sur laquelle est appuyé le piétement et le dossier en bois complètement tapissé. Des bras et des coussins tapissés sur mousse de polyuréthane indéformable de haute résistance. Il y a la possibilité d'incorporer des tables de centre en bois ou en cristal.

GLASGOW 1

82
90
74

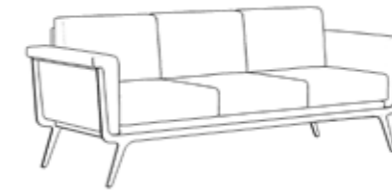
GLASGOW 3

82
208
74

MESA GLASGOW

43
98
62

Altura / Height / Haut
Anchura / Width / Large
Fondo / Depth / Fond

ACABADOS ESTRUCTURAS / STRUCTURES FINISHES / FINITIONS STRUCTURES
BLANCO

 White
Blanc

NEGRO

 Black
Noir

OTROS ACABADOS / OTHER FINISHES / AUTRES FINITIONS

Acabados y tipologías de bases, ruedas, brazos y mecanismos:
Consultar tarifa.

Finishes, types of bases, castors, armrest and mechanisms.
Check price list.

Finitions et types de piétement, roués, accoudoirs et mécanismes.
Consulter le tarif.

TAPICERÍAS / UPHOLSTERY / TAPISSERIES

Las sillas se pueden tapizar con cualquier tejido o piel de nuestro muestrario (pág. 294) o con tejidos suministrados por el cliente.

Chairs can be upholstered in a any fabric or leather of our sample book (pag. 294) or in COM.

Les chaises peuvent être tapissées avec n'importe quel tissu ou cuir de notre échantillonnage (pag. 294) Ou avec les tissus fournis par le client.

TRIPOLI

CONTRACT
& SOFT SEATING



TRIPOLI

CONTRACT
& SOFT SEATING



TRIPOLI
 CONTRACT & SOFT SEATING

Sillón de recepción formado por una monocarcasa de madera conformada completamente tapizada. Estructura de tubo de acero cromado de diámetro 26 mm. o de madera de haya maciza. Incorpora mesa de centro fabricada en varilla cromada y tapa en cristal de seguridad o madera.

TRIPOLI
 CONTRACT & SOFT SEATING

Contract chair made in a wood mono-shell, fully upholstered. Chromed steel structure with a 26 mm diameter tube or solid wood structure. Available coffee table with security glass or melamine top with chromed solid rod structure.

TRIPOLI
 CONTRACT & SOFT SEATING

Fauteuil de réception formée d'une monocarrosse en bois entièrement tapissée. Structure en tube d'acier chromé de 26 mm de diamètre ou de bois de hêtre massive. Il incorpore une table de centre fabriquée comme baquette chrome. Le plateau en cristal de sécurité ou en bois.

**TRIPOLI 1**

75
65
76

**TRIPOLI 2**

75
65
76

**MESA TRIPOLI**

40
70
50

Altura / Height / Haut
Anchura / Width / Large
Fondo / Depth / Fond

ACABADOS ESTRUCTURAS / STRUCTURES FINISHES / FINITIONS STRUCTURES

MADERA HAYA



Beech
Bois Hêtre

CROMO



Chrome
Chrome

OTROS ACABADOS / OTHER FINISHES / AUTRES FINITIONS

Acabados y tipologías de bases, ruedas, brazos y mecanismos:
Consultar tarifa.

Finishes, types of bases, castors, armrest and mechanisms.
Check price list.

Finitions et types de piètement, roués, accoudoirs et mécanismes.
Consulter le tarif.

TAPICERÍAS / UPHOLSTERY / TAPISSERIES

Las sillas se pueden tapizar con cualquier tejido o piel de nuestro muestrario (pág. 294) o con tejidos suministrados por el cliente.

Chairs can be upholstered in a any fabric or leather of our sample book (pag. 294) or in COM.

Les chaises peuvent être tapissées avec n'importe quel tissu ou cuir de notre échantillonnage (pag. 294) Ou avec les tissus fournis par le client.



Designer:
SIGFRIDO BILBAO

DAKAR

**CONTRACT
& SOFT SEATING**





DAKAR
 CONTRACT & SOFT SEATING

Serie de sillones de recepción y sala de juntas. Estructura y brazos en madera completamente tapizados. Respaldo cabecero fabricado en madera de haya conformada, tapizado una cara y barnizado o lacado por la otra. Mecanismo pistón a gas con base fija o giratoria (con o sin ruedas), a excepción del modelo con base de madera que es fijo.

DAKAR
 CONTRACT & SOFT SEATING

Chairs for receptions or meeting. Wood structure and arms fully upholstered. Back and headrest made in beech upholstered one side and painted or lacquered on the other. Gas lift mechanism with fixed or swivel base, except wood base which is fixed.

DAKAR
 CONTRACT & SOFT SEATING

Gamme de canapés d'accueil et salles à réunion. Structure et accoudoirs en bois complètement tapissés. Le dossier tête fabriqué en bois de hêtre tapissé au front et vernissage ou laqué au fond. Mécanisme à gas avec piètement fixe au tournant (avec ou sans roues). À l'exception du modèle avec le piètement en bois qui est fixe.



DAKAR 1
80/92
66
60



DAKAR 2
80/92
66
60



DAKAR 3
80/92
66
60



DAKAR 4
80
66
60

Altura / Height / Haut
Anchura / Width / Large
Fondo / Depth / Fond

ACABADOS RESPALDOS / BACKREST FINISHES / FINITION DE DOSSIERS

BLANCO

White
Blanc

NEGRO

Black
Noir

LACA RAL A ELEGIR

Other Lacquer
Laque Ral A Choisir

BARNIZ NATURAL

Natural Varnish
Verni Naturel

BARNIZ A ELEGIR

Other Varnish
Verni A Choisir
ACABADOS BASES / BASES FINISHES / FINITIONS PIÈTEMENTS

MADERA HAYA

Beech
Bois Hêtre

ALUMINIO PULIDO

Polished Aluminum
Aluminium Poli
OTROS ACABADOS / OTHER FINISHES / AUTRES FINITIONS

Acabados y tipologías de bases, ruedas, brazos y mecanismos:
Consultar tarifa.

Finishes, types of bases, castors, armrest and mechanisms.
Check price list.

Finitions et types de piètement, roués, accoudoirs et mécanismes.
Consulter le tarif.

TAPICERÍAS / UPHOLSTERY / TAPISSERIES

Las sillas se pueden tapizar con cualquier tejido o piel de nuestro muestrario (pág. 294) o con tejidos suministrados por el cliente.

Chairs can be upholstered in a any fabric or leather of our sample book (pag. 294) or in COM.

Les chaises peuvent être tapissées avec n'importe quel tissu ou cuir de notre échantillonnage (pag. 294) Ou avec les tissus fournis par le client.

Designer:
SIGFRIDO BILBAO

NIGER

**CONTRACT
& SOFT SEATING**



NIGER

CONTRACT
& SOFT SEATING



NIGER
 CONTRACT & SOFT SEATING

Serie de sillones de recepción y sala de juntas. Respaldo de aluminio lacado en diferentes colores y tapizado en el frente. Asiento en madera tapizada sobre espuma indeformable. Mecanismo pistón a gas con base fija o giratoria (con o sin ruedas), a excepción del modelo con base de madera que es fijo.

NIGER
 CONTRACT & SOFT SEATING

Chairs for receptions or meeting. Metal backrest lacquered in different colors, the back is upholstered on the front. Wood seat upholstered on non-deformable foam. Gas lift mechanism with fixed or swivel base, except wood base which is fixed.

NIGER
 CONTRACT & SOFT SEATING

Gamme de fauteuils d'accueil et salles à réunion. Dossier en aluminium laqué en différents couleurs et tapissé dans le front. Assise en bois tapissé sur une mousse indeformable. Mécanisme à gaz avec piètement fixe ou tournant (avec ou sans roues). À l'exception du modèle avec le piètement en bois qui est fixe.

NIGER 1
 72/84
 60
 56

NIGER 2
 72/84
 60
 56

NIGER 3
 72/84
 60
 56

NIGER 4
 80
 60
 56

Altura / Height / Haut
Anchura / Width / Large
Fondo / Depth / Fond

ACABADOS RESPALDOS / BACKREST FINISHES / FINITION DE DOSSIERS

BLANCO

White
Blanc

NEGRO

Black
Noir

ALUMINIO

Aluminum
Aluminium
ACABADOS BASES / BASES FINISHES / FINITIONS PIÈTEMENTS

MADERA DE HAYA

Beech
Bois Hêtre

ALUMINIO PULIDO

Polished Aluminum
Aluminium Poli
OTROS ACABADOS / OTHER FINISHES / AUTRES FINITIONS

Acabados y tipologías de bases, ruedas, brazos y mecanismos:
Consultar tarifa.

Finishes, types of bases, castors, armrest and mechanisms.
Check price list.

Finitions et types de piètement, roués, accoudoirs et mécanismes.
Consulter le tarif.

TAPICERÍAS / UPHOLSTERY / TAPISSERIES

Las sillas se pueden tapizar con cualquier tejido o piel de nuestro muestrario (pág. 294) o con tejidos suministrados por el cliente.

Chairs can be upholstered in a any fabric or leather of our sample book (pag. 294) or in COM.

Les chaises peuvent être tapissées avec n'importe quel tissu ou cuir de notre échantillonnage (pag. 294) Ou avec les tissus fournis par le client.

Designer:
SIGFRIDO BILBAO

SEVILLA

**CONTRACT
& SOFT SEATING**



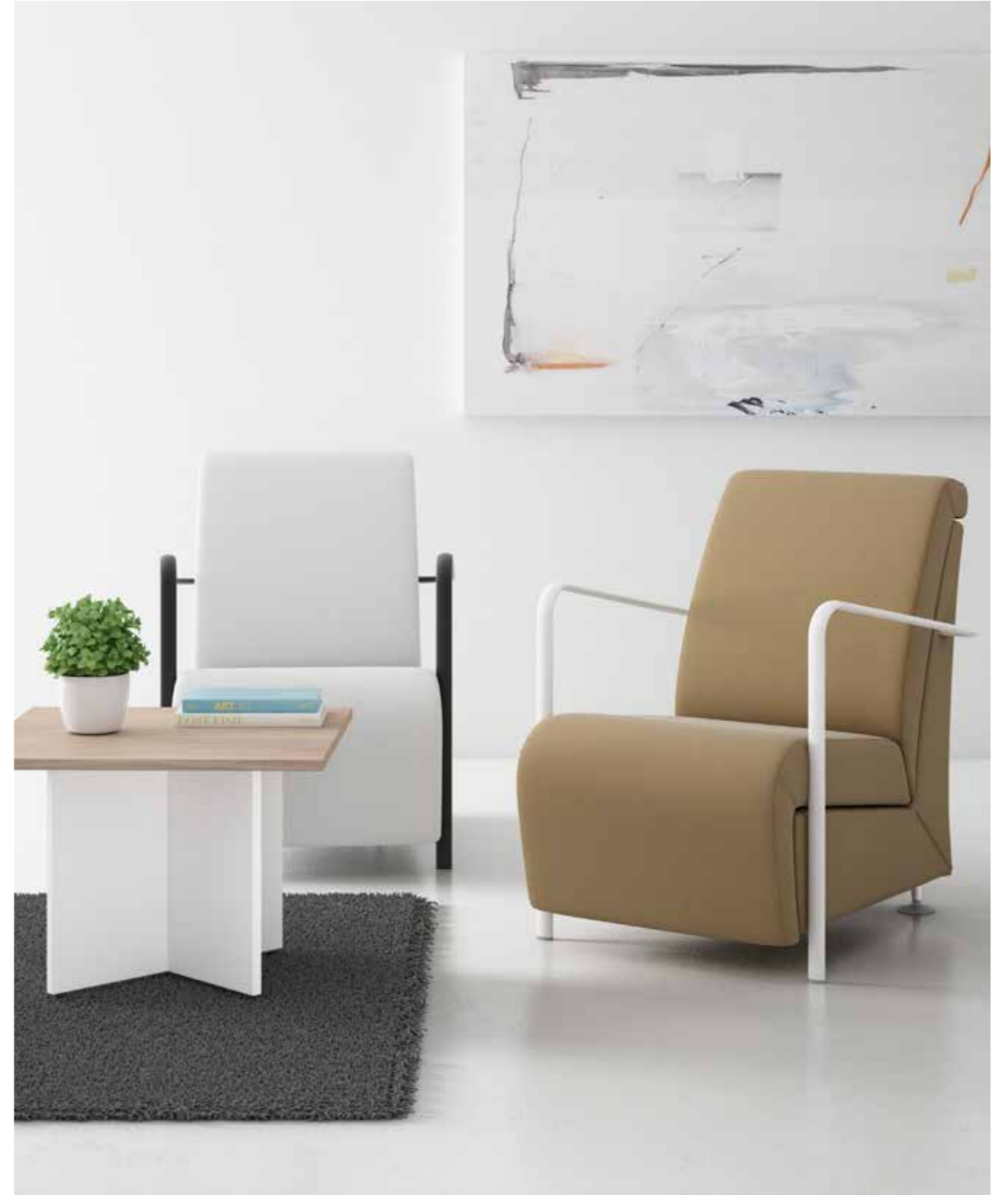

SEVILLA
 CONTRACT & SOFT SEATING

Sofá de recepción disponible en 1 y 3 plazas. Estructura de madera completamente tapizada. Suspensión mediante cintas elásticas. Cojines fabricados en espuma de poliuretano de alta resistencia. Brazos fabricados en tubo semioval acabados en pintura epoxi o cromados. Mesas de centro y rinconeras fabricadas en tablero laminado de 19 mm.

SEVILLA
 CONTRACT & SOFT SEATING

Sofa for reception, 1 or 3 seater. Wood frame fully upholstered. Suspension by rubber bands. Cushions in polyurethane high strength foam. Semi oval arms tube painted in epoxy or chrome finish. Available coffee and corner tables made of laminated board of 19 mm.

SEVILLA
 CONTRACT & SOFT SEATING

Sofa de recepcin disponible en 1 et 3 places. Structure en bois complètement tapissé. Suspension avec sangles élastiques. Coussins fabriqués en mailles de polyuréthane de haute résistance. Accoudoirs fabriqués en tube semi-oval laqués en peinture epoxy ou chromes. Tables de centre et rinconeras fabriqués en panneau laminé de 19 mm.

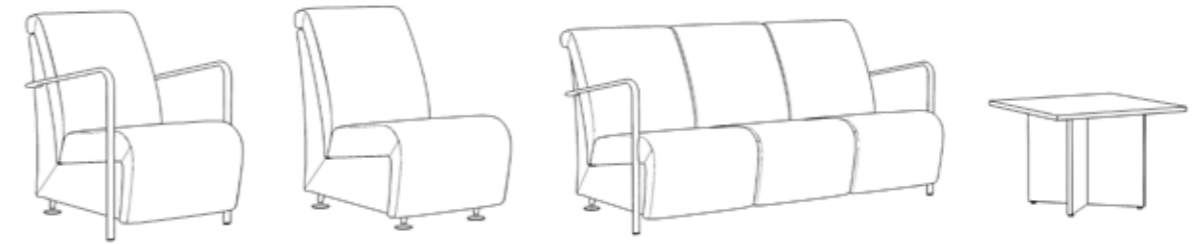
**SEVILLA 11**87
65
78**SEVILLA 11 SIN BRAZOS**87
60
78**SEVILLA 13**87
185
78**MESA SEVILLA**40
60/90
60/40
Altura / Height / Haut
Anchura / Width / Large
Fondo / Depth / Fond
**ACABADOS BRAZOS / ARMS FINISHES / FINITIONS D'ACCOUDOIRS**

BLANCO

White
Blanc

NEGRO

Black
Noir

GRIS

Grey
Gris

CROMO

Chrome
Chrome**OTROS ACABADOS / OTHER FINISHES / AUTRES FINITIONS**

Acabados y tipologías de bases, ruedas, brazos y mecanismos:
Consultar tarifa.

Finishes, types of bases, castors, armrest and mechanisms.
Check price list.

Finitions et types de piètement, roués, accoudoirs et mécanismes.
Consulter le tarif.

TAPICERÍAS / UPHOLSTERY / TAPISSERIES

Las sillas se pueden tapizar con cualquier tejido o piel de nuestro muestrario (pág. 294) o con tejidos suministrados por el cliente.

Chairs can be upholstered in a any fabric or leather of our sample book (pag. 294) or in COM.

Les chaises peuvent être tapissées avec n'importe quel tissu ou cuir de notre échantillonnage (pag. 294) Ou avec les tissus fournis par le client.

Designer:
SIGFRIDO BILBAO

VENECIA

**CONTRACT
& SOFT SEATING**



VENECIA

CONTRACT
& SOFT SEATING

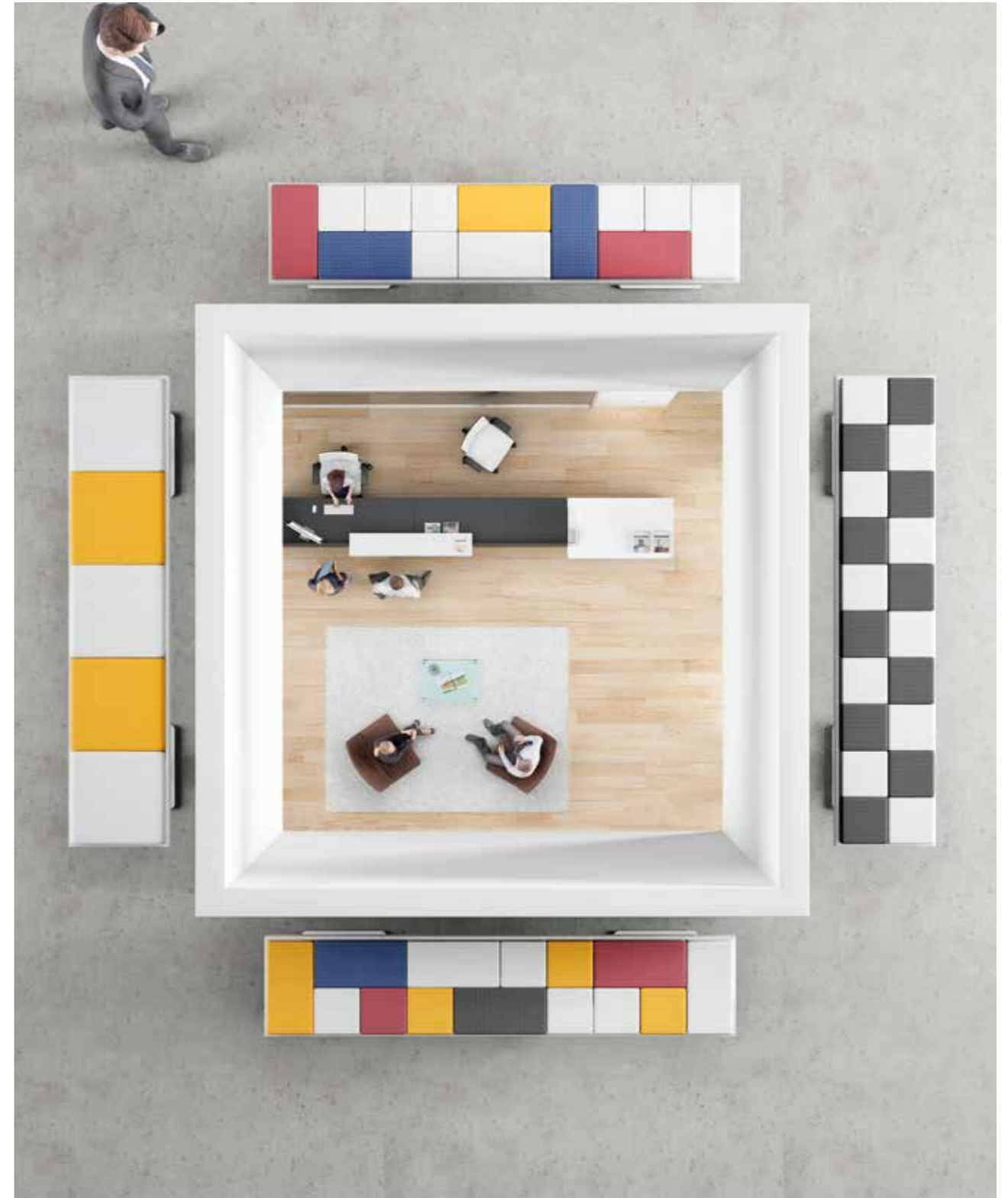

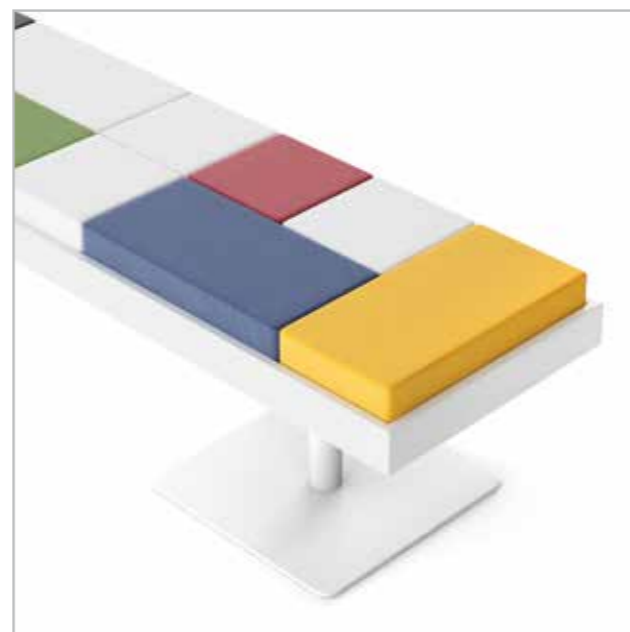
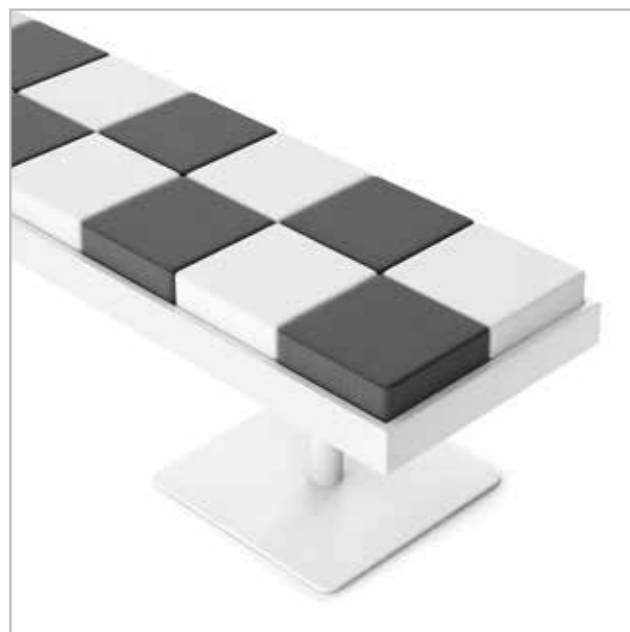
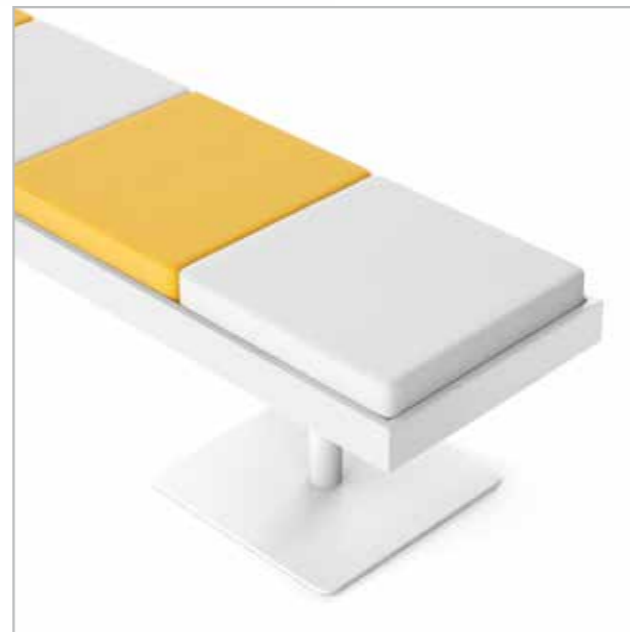
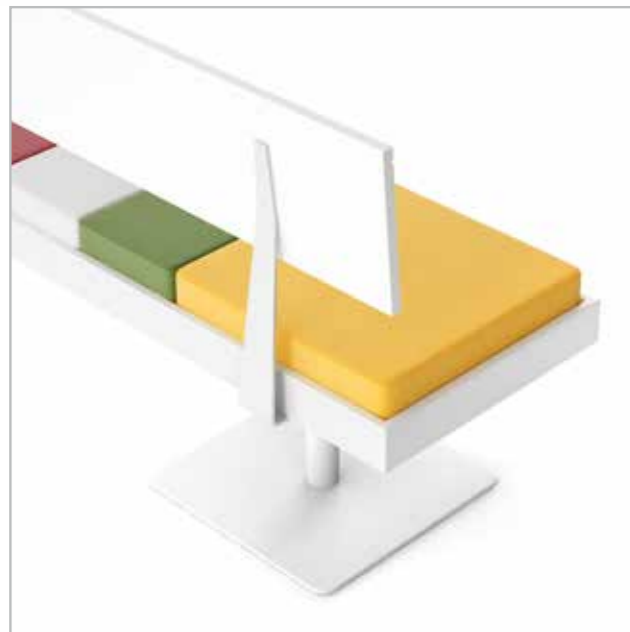
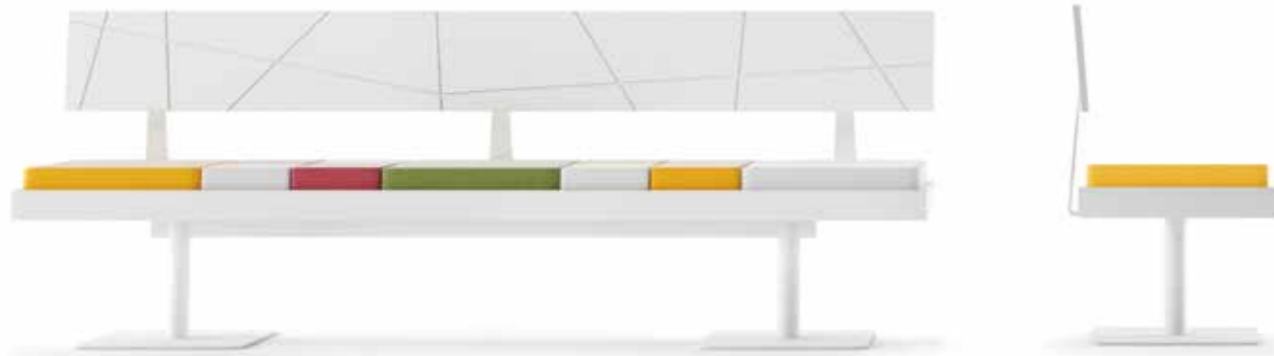
VENECIA
 CONTRACT & SOFT SEATING

Banco de espera con asiento fabricado en DM lacado blanco con tres tamaños de cojines fabricados con espuma densidad 40, tapizados en acabado GOYA e intercambiables entre sí. Respaldo opcional fabricado en DM lacado blanco y fijado al asiento mediante soportes metálicos. Estructura metálica acabada en epoxi color blanco y formada por dos pies unidos por una viga.

VENECIA
 CONTRACT & SOFT SEATING

Bench seating, seat manufactured in MDF lacquered, available in three different sizes of cushions, made in 40 foam density, all upholstered in GOYA textile and interchangeable. Available with backrest, manufactured also in MDF lacquered and fixed to the seat with metal supports. Metallic structure painted in white epoxy with two legs joined by a beam.

VENECIA
 CONTRACT & SOFT SEATING

Un banc d'attente avec assise tapissée en DM laqué blanche avec trois tailles de coussins fabriqués avec moelle d'une densité 40. Tapissés en GOYA et interchangeables entre si. Dossier optionnel fabriquée comme DM laqué blanc et fixé au siège au moyen des supports métalliques. Structure métallique fini en epoxy blanc et formée par deux pieds unis para une poutre.

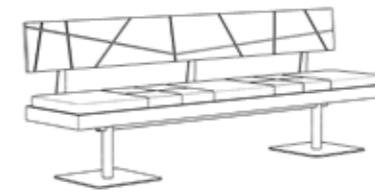
VENECIA C/RESPALDO

90
150/195/245
52

VENECIA

50
150/195/245
52

Altura / Height / Haut
Anchura / Width / Large
Fondo / Depth / Fond

ACABADOS METÁLICOS Y ESTRUCTURA / METAL FINISHES AND STRUCTURE / FINITIONS MÉTALLIQUES ET STRUCTURE
BLANCO

White
Blanc

OTROS ACABADOS / OTHER FINISHES / AUTRES FINITIONS

Acabados y tipologías de bases, ruedas, brazos y mecanismos:
Consultar tarifa.

Finishes, types of bases, castors, armrest and mechanisms.
Check price list.

Finitions et types de piètement, roués, accoudoirs et mécanismes.
Consulter le tarif.

TAPICERÍAS / UPHOLSTERY / TAPISSERIES

Las sillas se pueden tapizar con cualquier tejido o piel de nuestro muestrario (pág. 294) o con tejidos suministrados por el cliente.

Chairs can be upholstered in a any fabric or leather of our sample book (pag. 294) or in COM.

Les chaises peuvent être tapissées avec n'importe quel tissu ou cuir de notre échantillonnage (pag. 294) Ou avec les tissus fournis par le client.

Designer:
SIGFRIDO BILBAO

MALTA

**CONTRACT
& SOFT SEATING**



MALTA
 CONTRACT & SOFT SEATING

Banco monocarcasa fabricado en contrachapado de haya de 15 mm de espesor. Posibilidad de barnizar o lacar en cualquier tono. Parte delantera tapizada. Patas en madera maciza en el mismo acabado que la monocarcasa. Travesaño fabricado en chapa de acero, acabado epoxi color aluminio.

MALTA
 CONTRACT & SOFT SEATING

Bench, shell made of beech plywood 15mm thick. Available in varnish or lacquer. Upholstered on the front. Legs in solid wood in the same finish as the bench. Steel crossbar painted in aluminum epoxy finish..

MALTA
 CONTRACT & SOFT SEATING

Banc monocarcasse fabriqué en contreplaqué de hêtre de 15 mm d'épaisseur. Il y a possibilité de vernir ou laquer en n'importe quel ton. La partie de devant tapissée. Des pieds en bois massive dans le même fini que la monocarcasse. Traverse fabriquée en plaque d'acier fini en epoxy aluminium.

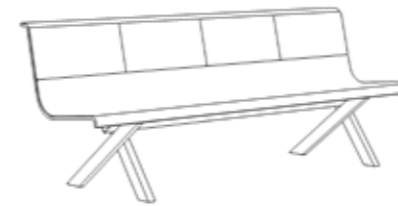

MALTA 4
 82
 210
 45

MALTA 3
 82
 158
 45

Altura / Height / Haut
 Anchura / Width / Large
 Fondo / Depth / Fond

ACABADOS RESPALDOS Y BASES / BACKREST AND BASES FINISHES / FINITION DE DOSSIERS ET PIÈTEMENTS

BLANCO



White
 Blanc

NEGRO



Black
 Noir

LACA RAL A ELEGIR



Other Lacquer
 Laque Ral A Choisir

BARNIZ NATURAL



Natural Varnish
 Verni Naturel

BARNIZ A ELEGIR



Other Varnish
 Verni A Choisir

OTROS ACABADOS / OTHER FINISHES / AUTRES FINITIONS

Acabados y tipologías de bases, ruedas, brazos y mecanismos:
 Consultar tarifa.

Finishes, types of bases, castors, armrest and mechanisms.
 Check price list.

Finitions et types de piètement, roués, accoudoirs et mécanismes.
 Consulter le tarif.

TAPICERÍAS / UPHOLSTERY / TAPISSERIES

Las sillas se pueden tapizar con cualquier tejido o piel de nuestro muestrario (pág. 294) o con tejidos suministrados por el cliente.

Chairs can be upholstered in a any fabric or leather of our sample book (pag. 294) or in COM.

Les chaises peuvent être tapissées avec n'importe quel tissu ou cuir de notre échantillonnage (pag. 294) Ou avec les tissus fournis par le client.

Designer:
SIGFRIDO BILBAO

LORCA

CONTRACT
& SOFT SEATING



LORCA
 CONTRACT & SOFT SEATING

Bancada fabricada con estructura de bilaminado acabado en cualquier diseño de ISMOBEL. Respaldos, barnizados o lacados, fabricados en madera contrachapada de haya conformada de grosor variable 8-13mm. (colocados en diferentes orientaciones). Asientos tapizados sobre espuma de poliuretano de alta resistencia. Ángulos de unión y jardineras opcionales.

LORCA
 CONTRACT & SOFT SEATING

Bench made with a bilaminate structure finished in any ISMOBEL design. Backrests, varnished or lacquered, made of shaped beech plywood of variable thickness 8-13mm. (placed in different orientations). Upholstered seats on high resistance polyurethane foam. Available joining angles and planters.

LORCA
 CONTRACT & SOFT SEATING

Banc fait avec une structure bilaminée finie dans n'importe quelle conception ISMOBEL. Dossiers, vernis ou laqués, en contreplaqué de hêtre profilé d'épaisseur variable 8-13 mm. (placé dans différentes orientations). Sièges rembourrés en mousse de polyuréthane haute résistance. Angles de jonction et jardinières en option.



LORCA 3	LORCA 4	LORCA 5	
85	85	85	Altura / Height / Haut
170	230	285	Anchura / Width / Large
50	50	50	Fondo / Depth / Fond

ACABADOS RESPALDOS / BACKREST FINISHES / FINITION DE DOSSIERS

BLANCO	NEGRO	LACA RAL A ELEGIR	BARNIZ NATURAL	BARNIZ A ELEGIR
White Blanc	Black Noir	Other Lacquer Laque Ral A Choisir	Natural Varnish Verni Naturel	Other Varnish Verni A Choisir

ACABADOS ESTRUCTURAS / STRUCTURES FINISHES / FINITIONS STRUCTURES
MELAMINA

Melamine
Melamine

OTROS ACABADOS / OTHER FINISHES / AUTRES FINITIONS

Acabados y tipologías de bases, ruedas, brazos y mecanismos:
Consultar tarifa.

Finishes, types of bases, castors, armrest and mechanisms.
Check price list.

Finitions et types de piètement, roués, accoudoirs et mécanismes.
Consulter le tarif.

TAPICERÍAS / UPHOLSTERY / TAPISSERIES

Las sillas se pueden tapizar con cualquier tejido o piel de nuestro muestrario (pág. 294) o con tejidos suministrados por el cliente.

Chairs can be upholstered in a any fabric or leather of our sample book (pag. 294) or in COM.

Les chaises peuvent être tapissées avec n'importe quel tissu ou cuir de notre échantillonnage (pag. 294) Ou avec les tissus fournis par le client.

ALBERTA

CONTRACT
& SOFT SEATING



ALBERTA

CONTRACT
& SOFT SEATING



ALBERTA
 CONTRACT & SOFT SEATING

Sillón completamente tapizado sobre espuma inyectada de alta densidad indeformable. Brazos estructurales tapizados. Estructura de 4 patas de madera maciza de haya o 4 patas metálicas acabada en cromo. Posibilidad de incorporar base giratoria piramidal en poliamida de 4 radios con topes o ruedas y base giratoria piramidal metálica (acabado cromo) de 4 radios con topes o de 5 radios con ruedas.

ALBERTA
 CONTRACT & SOFT SEATING

Reception chair fully upholstered in non-deformable high density foam. Upholstered arms. Available with 4 legs solid beech wood structure, 4 chromed legs structure. Possibility of incorporating 4-castors polyamide pyramidal swivel base with stops or wheels and metallic pyramidal swivel base (chrome finish) with 4 castors with stops or 5 spokes with wheels.

ALBERTA
 CONTRACT & SOFT SEATING

Fauteuil complètement tapissé sur une mousse injectée de haute densité indéformable. Accoudoirs structurels tapissés. Structure de 4 pieds en bois massive de hêtre. 4 Pieds métalliques fini en chrome. Possibilité d'incorporer la base giratoire pyramidale en poliamide de 4 radios avec topes ou roues et base giratoire pyramidale métallique (acabado cromo) de 4 radios avec topes ou 5 radios avec ruedas.



ALBERTA 1	ALBERTA 2	ALBERTA 3	ALBERTA 4	ALBERTA 5	ALBERTA M	
80	80	80	80	80	42	Altura / Height / Haut
50	50	50	50	50	60	Anchura / Width / Large
50	50	50	50	50	60	Fondo / Depth / Fond

ACABADOS BASES / BASES FINISHES / FINITIONS PIÈTEMENTS

BLANCO	NEGRO	CROMO	MADERA-HAYA
White Blanc	Black Noir	Chrome Chrome	Beech Bois Hêtre

OTROS ACABADOS / OTHER FINISHES / AUTRES FINITIONS

Acabados y tipologías de bases, ruedas, brazos y mecanismos:
Consultar tarifa.

Finishes, types of bases, castors, armrest and mechanisms.
Check price list.

Finitions et types de piètement, roués, accoudoirs et mécanismes.
Consultar le tarif.

TAPICERÍAS / UPHOLSTERY / TAPISSERIES

Las sillas se pueden tapizar con cualquier tejido o piel de nuestro muestrario (pág. 294) o con tejidos suministrados por el cliente.

Chairs can be upholstered in a any fabric or leather of our sample book (pag. 294) or in COM.

Les chaises peuvent être tapissées avec n'importe quel tissu ou cuir de notre échantillonnage (pag. 294) Ou avec les tissus fournis par le client.

MEMPHIS

CONTRACT
& SOFT SEATING



MEMPHIS

CONTRACT
& SOFT SEATING

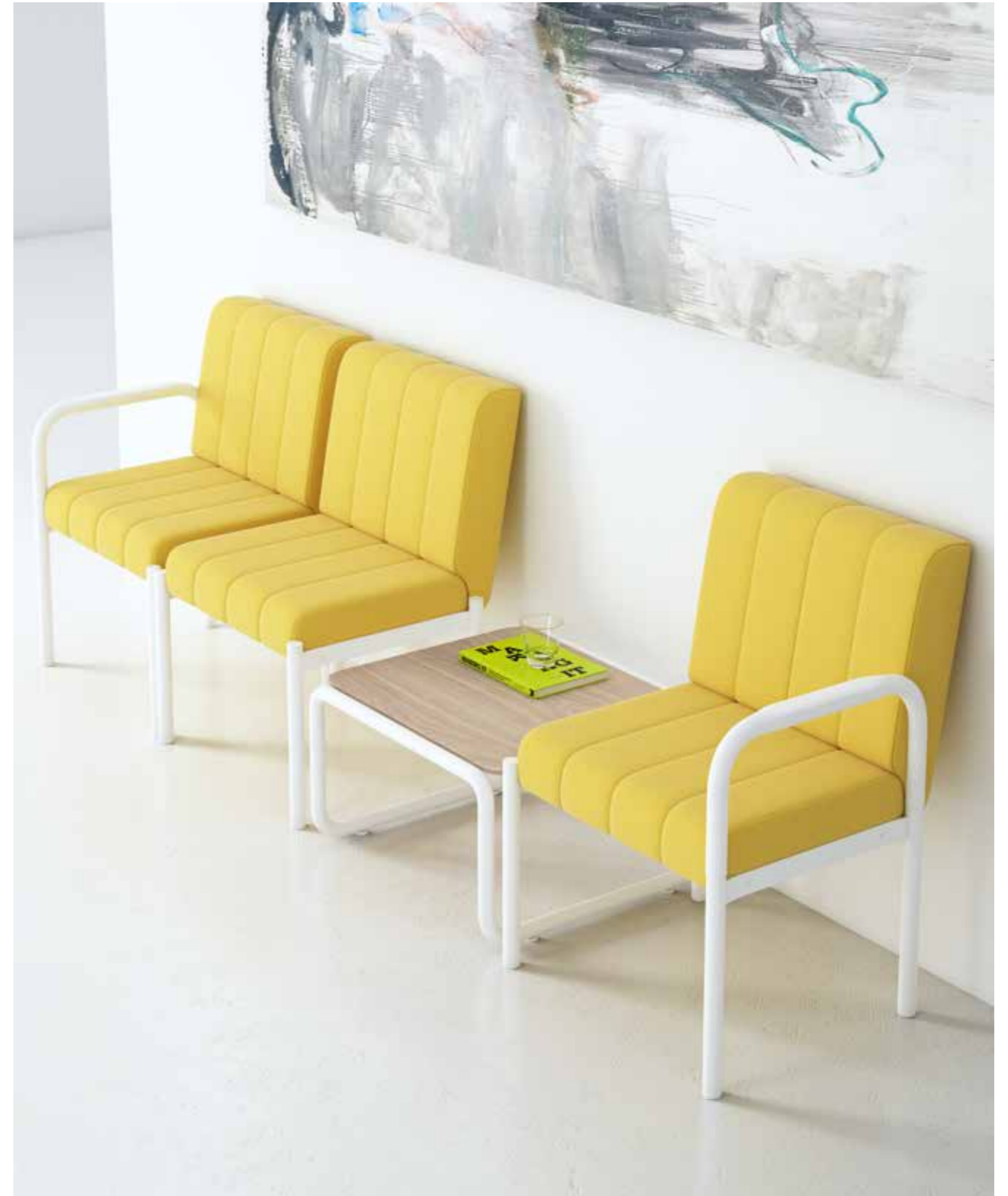

MEMPHIS
 CONTRACT & SOFT SEATING

Módulo de recepción con estructura metálica de 4 patas acabada en pintura epoxi color negro ó blanco. Inyectado sobre espuma inyectada de alta densidad indeformable sobre armazón de acero. Mesas auxiliares de tubo redondo curvado con encimeras de madera o cristal.

MEMPHIS
 CONTRACT & SOFT SEATING

Bench, shell made of beech plywood 15mm thick. Available in varnish or lacquer. Steel crossbar and legs (with levelers) painted in aluminum epoxy finish. Available with arms and tables with the same finish than bench.

MEMPHIS
 CONTRACT & SOFT SEATING

Produits pour hall d'accueil avec structure métallique d 4 pieds fini en peinture de epoxy couleur noir ou blanc. Injecté sur une mousse injectée de haute densité indeformable sur une armature en acier. Tables auxiliaires de tube rond. Courbé avec plateaux d'un bois ou un cristal.

**MEMPHIS**

75

65

76

**MESA MEMPHIS**

33

60 / 100

53

Altura / Height / Haut**Anchura** / Width / Large**Fondo** / Depth / Fond**ACABADOS METÁLICOS Y PLÁSTICOS / METAL FINISHES & PLASTICS / FINITION DE PLASTIQUES ET MÉTALLIQUES**

BLANCO

White
Blanc

NEGRO

Black
Noir**OTROS ACABADOS / OTHER FINISHES / AUTRES FINITIONS**

Acabados y tipologías de bases, ruedas, brazos y mecanismos:
Consultar tarifa.

Finishes, types of bases, castors, armrest and mechanisms.
Check price list.

Finitions et types de piètement, roués, accoudoirs et mécanismes.
Consulter le tarif.

TAPICERÍAS / UPHOLSTERY / TAPISSERIES

Las sillas se pueden tapizar con cualquier tejido o piel de nuestro muestrario (pág. 294) o con tejidos suministrados por el cliente.

Chairs can be upholstered in a any fabric or leather of our sample book (pag. 294) or in COM.

Les chaises peuvent être tapissées avec n'importe quel tissu ou cuir de notre échantillonnage (pag. 294) Ou avec les tissus fournis par le client.

Designer:
SCAGNELLATO / FERRARESE + BERTOLINI

ANGOLA

**CONTRACT
& SOFT SEATING**



ANGOLA
CONTRACT & SOFT SEATING

Taburete giratorio con asiento tapizado y regulable en altura. Base oscilante 20°.



ANGOLA
CONTRACT & SOFT SEATING

Swivel stool with upholstered and height-adjustable seat. Oscillating base 20°.

ANGOLA
CONTRACT & SOFT SEATING

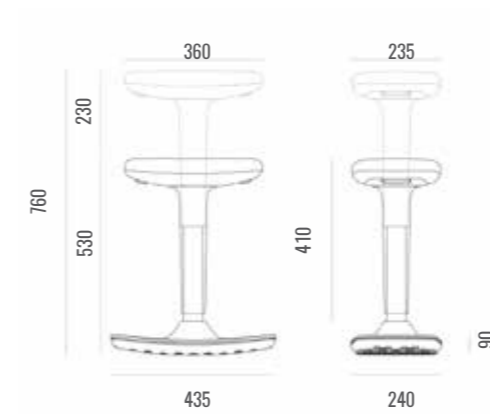
Tabouret pivotant avec assise tapissée et réglable en hauteur. Base oscillante 20°.

ACABADOS PLÁSTICOS / PLASTIC FINISHES / FINITIONS PLASTIQUES

BLANCO	NEGRO	ROJO
		
White Blanc	Black Noir	Red Rouge

TAPICERÍAS / UPHOLSTERY / TAPISSERIES

Las sillas se pueden tapizar con cualquier tejido o piel de nuestro muestrario (pág. 294) o con tejidos suministrados por el cliente.

Chairs can be upholstered in any fabric or leather of our sample book (pag. 294) or in COM.

Les chaises peuvent être tapissées avec n'importe quel tissu ou cuir de notre échantillonnage (pag. 294) Ou avec les tissus fournis par le client.

VANCOUVER

CONTRACT
& SOFT SEATING



VANCOUVER

CONTRACT
& SOFT SEATING



VANCOUVER
 CONTRACT & SOFT SEATING

Modelo 1 y 2:

Serie de mesas bajas, medias o altas con diferentes estructuras cromadas y encimeras en diferentes acabados.

Modelo 3, 4 y 5:

Serie de mesas bajas con 4 patas metálicas cuadradas en color blanco y negro y diferentes formas y medidas de encimeras.

Disponen también de puff tapizados.

VANCOUVER
 CONTRACT & SOFT SEATING

Model 1 and 2:

Coffee tables series, low, medium and high tables with chromed structure. Tops in different finishes.

Modelo 3, 4 and 5:

Series of low coffee tables with 4 square metal legs in black and white and different shapes and sizes of tops.

Available upholstered puffs.

VANCOUVER
 CONTRACT & SOFT SEATING

Modèle 1 et 2:

Une série de basses tables moyennes ou hautes avec différentes structures chromées et plateaux dans différents achevés.

Modèle 3,4, et 5:

Série de tables basses avec 4 pieds carrés en métal noir et blanc et différentes formes et tailles de plateaux.

Ils disposent aussi de puff des tapisseries.

VANCOUVER 1

47 / 73 / 110
60 / 80 / 60
60 / 80 / 60

VANCOUVER 2

47 / 73 / 110
60 / 80 / 60
60 / 80 / 60

VANCOUVER 3

45
60
60

VANCOUVER 4

45
70
52

VANCOUVER 5

45
120
40

VANCOUVER PUFF

37 / 47
40
40

Altura / Height / Haut
Anchura / Width / Large
Fondo / Depth / Fond

ENCIMERA / TOPS / PLATEAUX
MELAMINA

Melamine
Melamine

FENÓLICO

Phenolic
Fenolico

METÁLICOS / METAL PARTS / MÉTALLIQUES
CROMO

Chrome
Chrome

BLANCO

White
Blanc

NEGRO

Black
Noir

OTROS ACABADOS / OTHER FINISHES / AUTRES FINITIONS

Acabados y tipologías de bases, ruedas, brazos y mecanismos:
Consultar tarifa.

Finishes, types of bases, castors, armrest and mechanisms.
Check price list.

Finitions et types de piètement, roués, accoudoirs et mécanismes.
Consulter le tarif.

TAPICERÍAS / UPHOLSTERY / TAPISSERIES

Las sillas se pueden tapizar con cualquier tejido o piel de nuestro muestrario (pág. 294) o con tejidos suministrados por el cliente.

Chairs can be upholstered in a any fabric or leather of our sample book (pag. 294) or in COM.

Les chaises peuvent être tapissées avec n'importe quel tissu ou cuir de notre échantillonnage (pag. 294) Ou avec les tissus fournis par le client.



**EL CONOCIMIENTO HUMANO
SE BASA EN DOS PALABRAS:
CONFIAR Y ESPERAR**

ALEJANDRO DUMAS

"Novelista y dramaturgo francés."

"THE HUMAN KNOWLEDGE
IT IS BASED ON TWO WORDS:
TRUST AND WAIT "

Alejandro Dumas

"French novelist and playwright."

"LA CONNAISSANCE HUMAINE
IL EST BASÉ SUR DEUX MOTS:
CONFIANCE ET ATTENDRE "

Alejandro Dumas

"Romancier et dramaturge français."

BANCADAS

Bench / Banque

FRESNO 286

IOWA 288

JAMAICA 290

VIENA 292

FRESNO

BANCADAS
Bench / Banque



IOWA

BANCADAS
Bench / Banque



JAMAICA

BANCADAS
Bench / Banque



VIENA

BANCADAS

Bench / Banque



BANCADAS

Serie de bancadas de recepción con patas fabricadas en poliamida de color negro o de inyección de aluminio pulido brillo. Las patas se unen entre ellas y al bastidor del asiento mediante una viga metálica pintada en color negro. Consultar la silla de colectividades de cada modelo de bancada para ver las diferentes opciones de cada una de ellas.

BANCADAS

Serie of reception benches with legs made of black polyamide or polished aluminum injection. The legs are joined to each other and to the seat frame by means of a metallic beam painted in black. Consult the group chair of each bench model to see the different options for each one

BANCADAS

Série de bancs de réception avec pieds en polyamide noir ou injection d'aluminium poli poli. Les jambes sont jointes entre elles et au cadre du siège au moyen d'une poutre métallique peinte en noir. Consultez le président du groupe de chaque modèle de banc pour voir les différentes options pour chacun d'eux.



FRESNO	IOWA	VIENA	JAMAICA	Altura / Height / Haut
82	82	81	84	
105/185/246/295	123/185/246/295	123/185/246/295	121/177/233/295	Anchura / Width / Large
60	65	60	60	Fondo / Depth / Fond

BASES / BASES / PIÉMENTS

NEGRO



Black
Noir

ALUMINIO PULIDO



Polished Aluminum
Aluminium Poli

ACABADOS PLÁSTICOS / PLASTIC FINISHES / FINITIONS PLASTIQUES

Consultar el catálogo de cada modelo.

Consult the catalog of our model.

Consultez le catalogue de chaque modèle.

ACABADOS MALLAS / MESH FINISHES / FINITIONS MAILLES

BLANCO



White
Blanc

GRIS



Grey
Gris

NEGRO



Black
Noir

BURDEOS



Bordeaux
Bordeaux

AZUL



Blue
Bleu

VERDE



Green
Vert

MELOCOTÓN



Peach
Pêche

VISÓN



Mink
Vison

OTROS ACABADOS / OTHER FINISHES / AUTRES FINITIONS

Acabados y tipologías de bases, ruedas, brazos y mecanismos:
Consultar tarifa.

Finishes, types of bases, castors, armrest and mechanisms.
Check price list.

Finitions et types de piètement, roués, accoudoirs et mécanismes.
Consultar le tarif.

TAPICERÍAS / UPHOLSTERY / TAPISSERIES

Las sillas se pueden tapizar con cualquier tejido o piel de nuestro muestrario (pág. 294) o con tejidos suministrados por el cliente.

Chairs can be upholstered in a any fabric or leather of our sample book (pag. 294) or in COM.

Les chaises peuvent être tapissées avec n'importe quel tissu ou cuir de notre échantillonnage (pag. 294) Ou avec les tissus fournis par le client.



**CONSULTAR
DISPONIBILIDAD**
DE OTROS COLORES
PARA CANTIDADES

**ASK FOR
AVAILABILITY**
FOR OTHER COLORS
FOR LARGE
QUANTITIES

**VÉRIFIER LA
DISPONIBILITÉ**
POUR D'ANTRES
COULEURS POUR
GRANDES QUANTITÉS

ACABADOS

Finishes / Finitions

BONDAI	296
BERING	296
BALI	297
GOYA	297
BASIC F.R.	298
PUMA F.R.	298
RADIO	299
SUMMANO F.R.	299
TORINO	300
VALENCIA	300
SQUARE F.R.	301
KING ELAST	301
PIEL	302
MALLA	302
MALLA NICEA	303

BONDAI [GRUPO 1]

ANCHO: 140 cm
 PESO: 350 gr/ml
 100% Poliéster
 Inflamabilidad: EN 1021-1/2
 Resistencia Abrasión 150.000 c.Martindale



BALI [GRUPO 1]

ANCHO: 140 cm
 PESO: 420 gr/ml
 100% Poliolefina
 Inflamabilidad: EN 1021-1 2006 (Cigarrillo)
 Resistencia Abrasión 100.000 c.Martindale

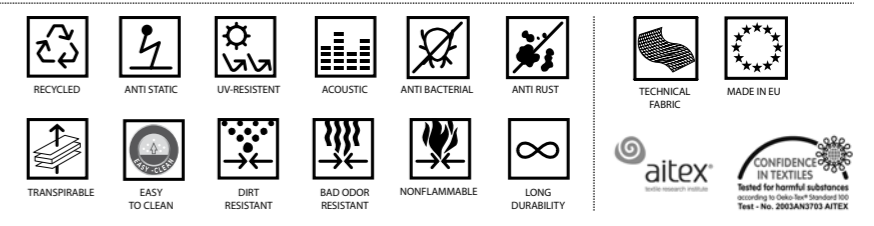

BERING [GRUPO 1]

ANCHO: 140 cm
 PESO: 605 gr/ml
 100% PVC
 100% Poliéster (base)
 Inflamabilidad: EN 1021-1 (Cigarrillo)
 Resistencia Abrasión 100.000 c.Martindale



GOYA [GRUPO 1]

ANCHO: 140 cm
 PESO: 355 gr/ml
 100% Poliolefina
 Inflamabilidad: EN 1021-1 2006 (Cigarrillo)
 Resistencia Abrasión 100.000 c.Martindale

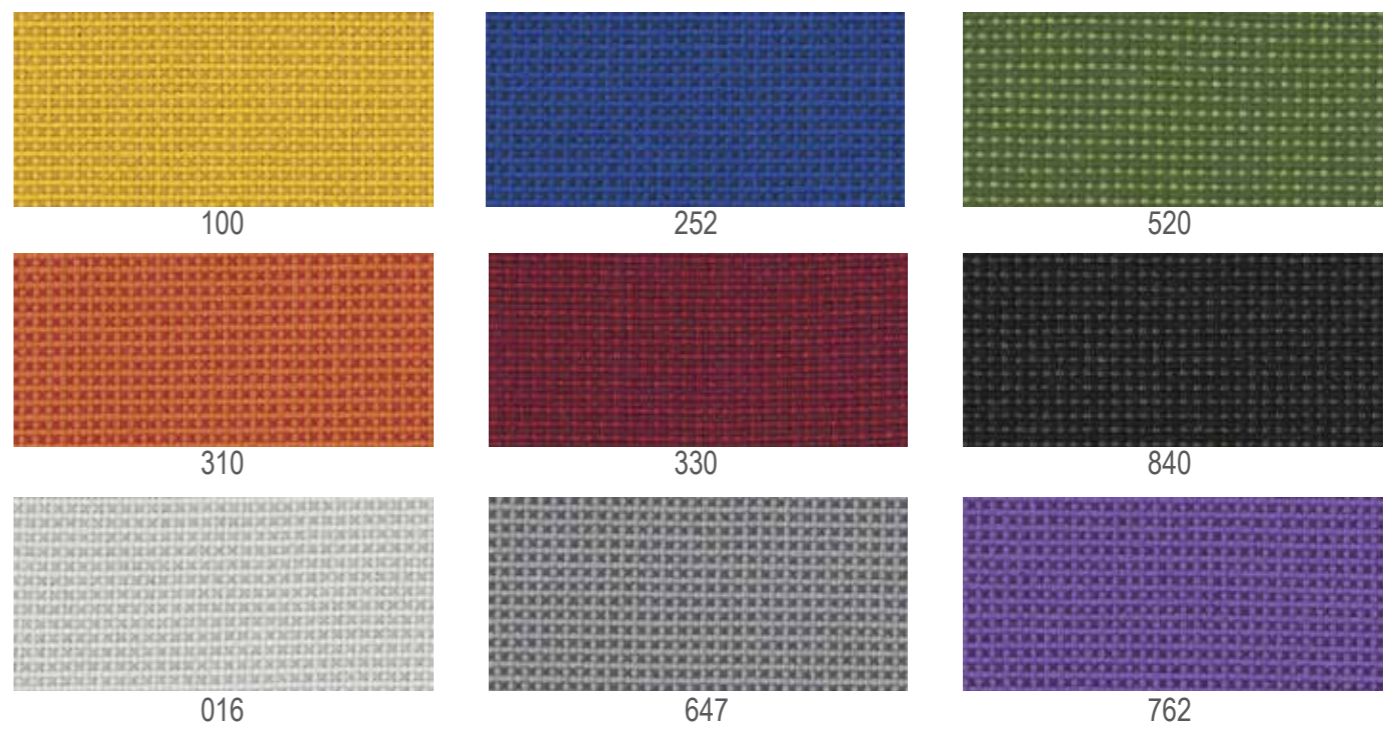
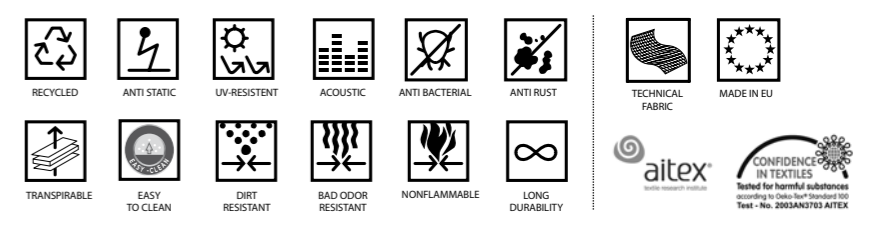

BASIC F.R. [GRUPO 1]



ANCHO: 140 cm
 PESO: 470 gr/ml
 100% Poliéster

Ignifugo: EN 1021-1/2
 Resistencia Abrasión 100.000 c.Martindale



106



088



755



462



098

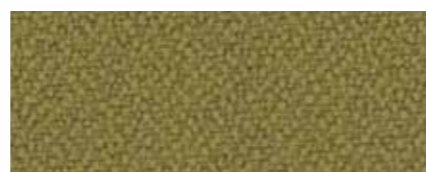

077



005



084



170



315



108



009

PUMA F.R. [GRUPO 2]



ANCHO: 140 cm
 PESO: 700 gr/ml
 79% PVC
 21% PES

Ignifugo: EN 1021-1/2
 Resistencia Abrasión 100.000 c.Martindale



800

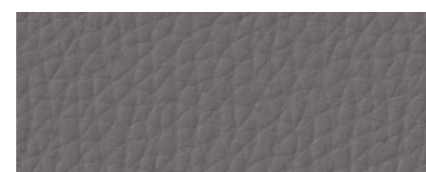

610



780



210



045



421

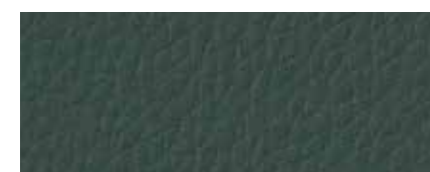

580



350

RADIO [GRUPO 2]



ANCHO: 140 cm
 PESO: 560 gr/ml
 100% Poliéster FR

Ignifugo: EN 1021-1/2
 Resistencia Abrasión 80.000 c.Martindale

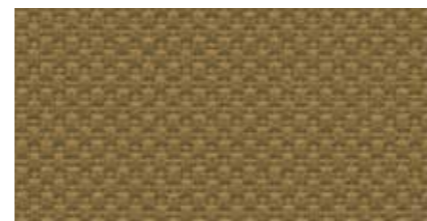

2021

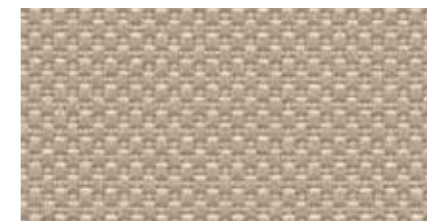

1010



3082



4046



4027

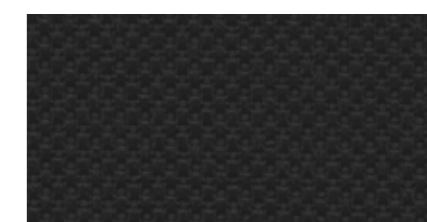

8033



8027

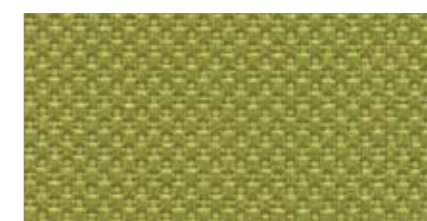

7025



6075

SUMMANO F.R. [GRUPO 2]



ANCHO: 140 cm
 PESO: 375 gr/ml
 100% Poliéster FR

Ignifugo: EN 1021-1/2
 Resistencia Abrasión 100.000 c.Martindale



01



03



05



09

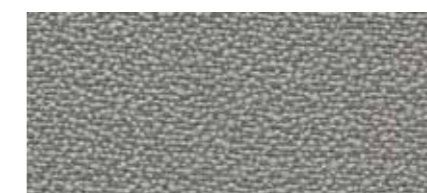

27

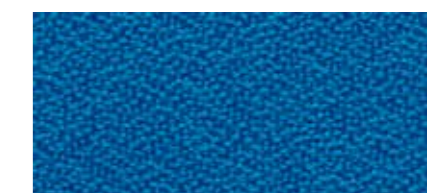

29

TORINO [GRUPO 2]



ANCHO: 140 cm
 PESO: 365 gr/ ml
 100% Poliéster TREVIRA CS
 Ignífugo: EN 1021-1/2
 Resistencia Abrasión: 70.000 c.Martindale

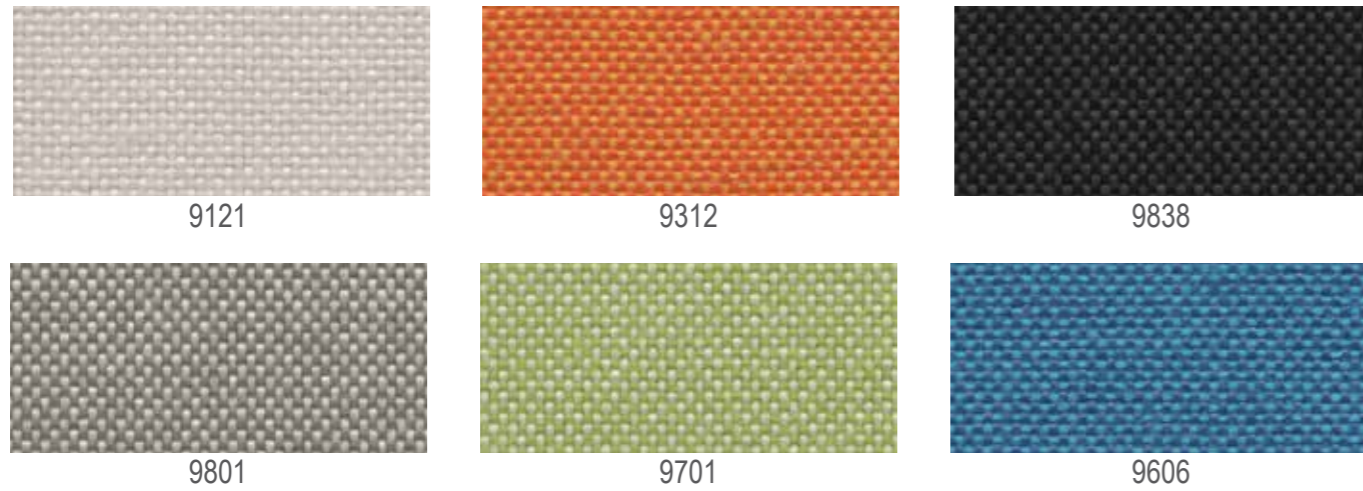

SQUARE F.R. [GRUPO 3]



ANCHO: 140 cm
 PESO: 553 gr/ ml
 100% Poliéster FR
 Ignífugo: EN 1021-1/2
 Resistencia Abrasión: 100.000 c.Martindale

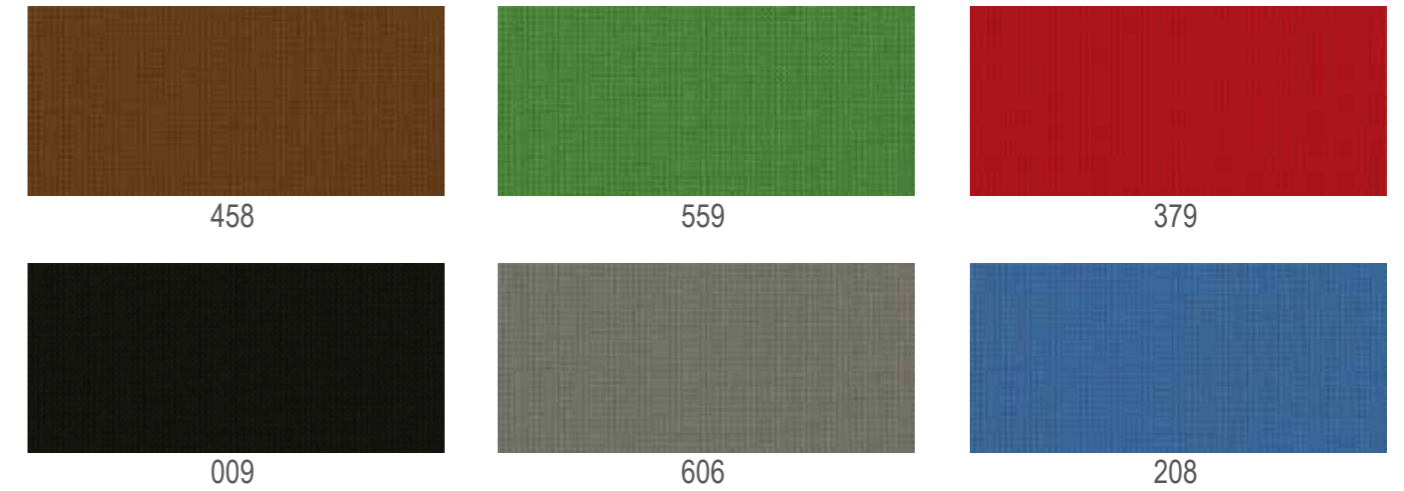

VALENCIA [GRUPO 3]



ANCHO: 137 cm
 PESO: 650 gr/ m²
 100% PVC
 100% Poliéster (base)
 Ignífugo: EN 1021-1/2
 Resistencia abrasión: 300.000 c.Martindale

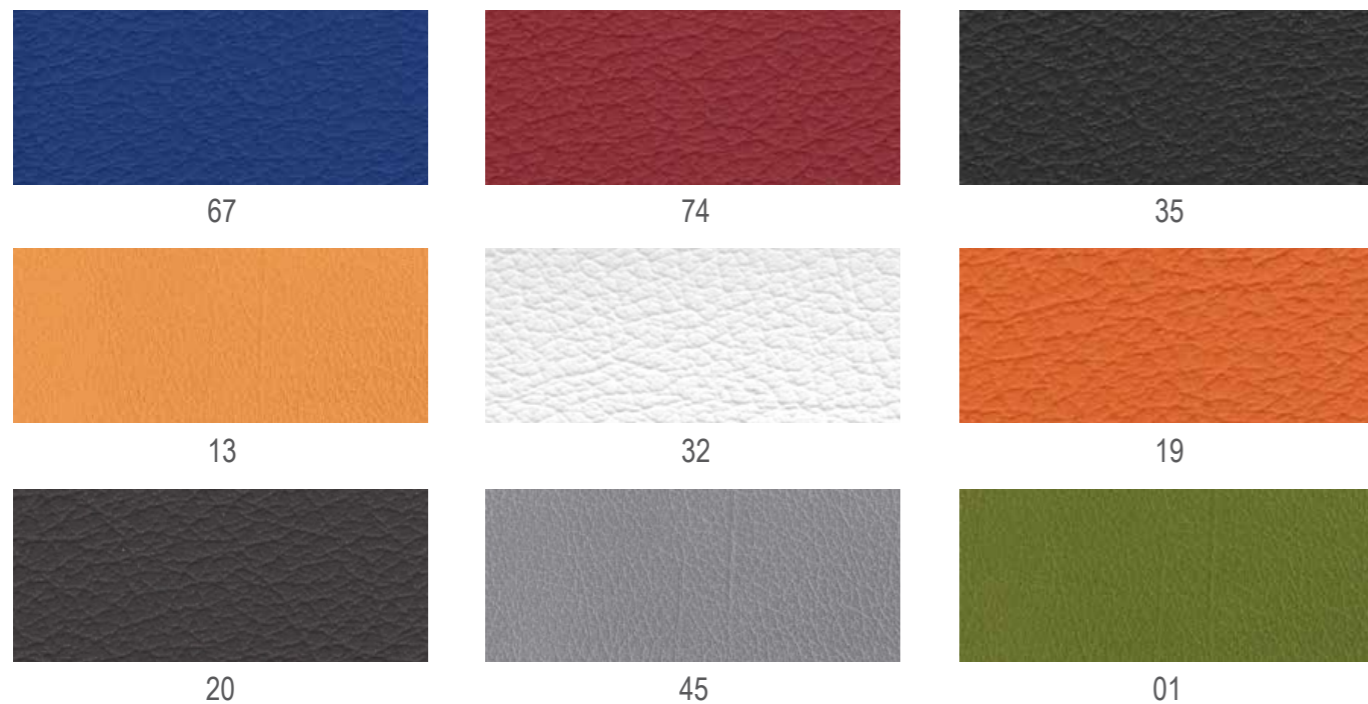
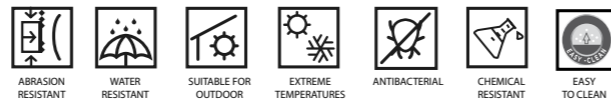

KING ELAST [GRUPO 3]



ANCHO: 140 cm
 PESO: 365 gr/ m²
 100% Poliéster (base)
 Ignífugo: EN 1021-1/2
 Resistencia abrasión: 80.000 c.Martindale

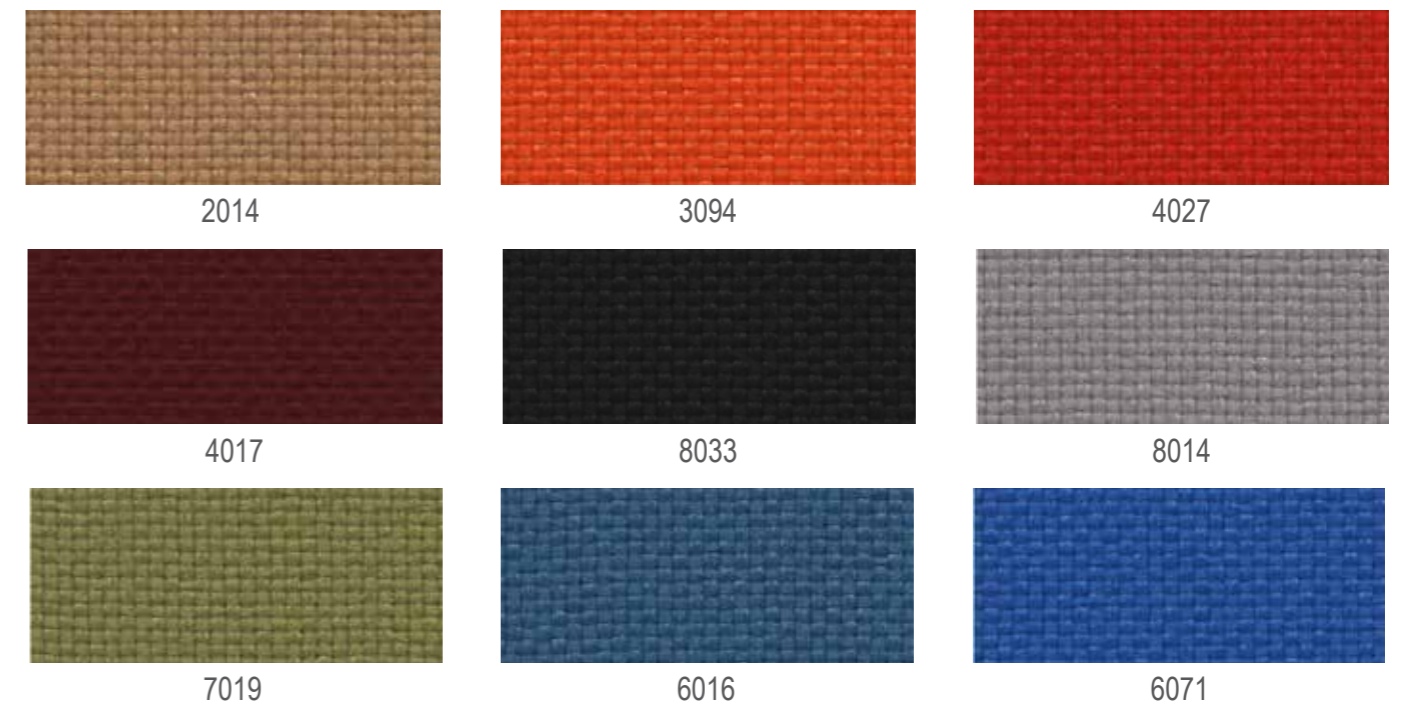

PIEL

MEDIDA DE PIEZA: 4,5 m²

Limpieza: Paño Húmedo



Negro



Marrón



430

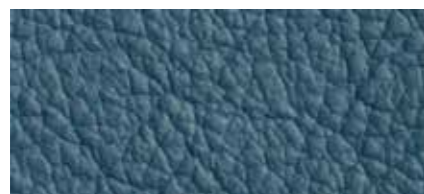

447

MALLA



ANCHO: 150 cm
 PESO: 340gr/ ml
 100% Poliéster
 Ignífugo: EN 1021-1/2
 Resistencia Abrasión: 90.000 c.Martindale

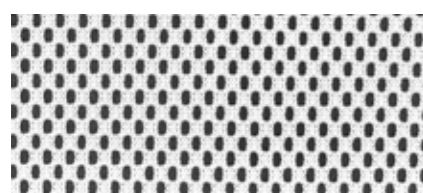
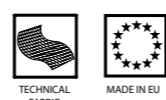

BLANCO

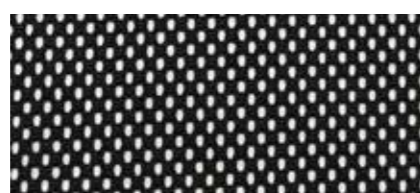

NEGRO



AZUL

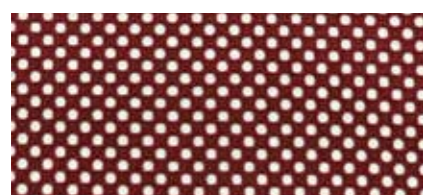

BURDEOS



VERDE

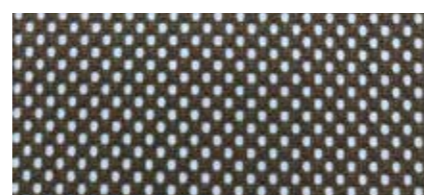

VISÓN



MELOCOTÓN



GRIS

MALLA NICEA

ANCHO: 140 cm
 PESO: 460 gr/ ml
 100% PES
 Resistencia Abrasión: 100.000 c.Martindale



Tejido únicamente aplicable para el respaldo de la silla Nicea



090



001



333

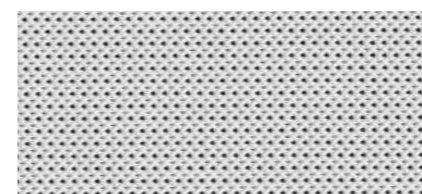

1000



052

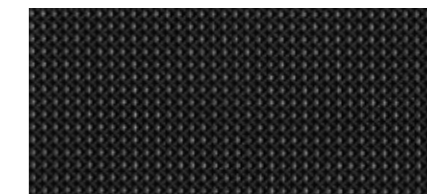

9000

NOTA:

Los colores de estas páginas pueden sufrir algún cambio con respecto a la muestra real debido a los procesos de impresión del catálogo.

Solicite una muestra física si desea asegurarse del acabado final.

NOTE:

The colors on these pages may have some difference from the physical sample due to catalogue printing procedure.

Request a physical sample if you want to make sure the final finish.

NOTE:

Les couleurs de ces pages peuvent avoir un changement avec rapport à l'échantillon réel en raison de l'impression du catalogue.

Vous pouvez nous solliciter un échantillon physique pour vous assurer du terminaison finale.

**LAS VERDADERAS
PREGUNTAS SON:
¿RESUELVE EL PROBLEMA?
¿CÓMO SE VERÁ EN 10 AÑOS?
¿SIRVE?**

CHARLES EAMES

Charles Eames fue un arquitecto, diseñador y director de cine estadounidense. Junto a su esposa Ray, es responsable de numerosos diseños convertidos ya en clásicos del siglo XX"

"The true ones questions are:
- RESOLVE THE PROBLEM ?
- HOW WILL IT LOOK IN 10 YEARS?
- IT SERVES ?"

Charles Eames

"Charles Eames was an American architect, designer and film director. Together with his wife Ray, he is responsible for numerous designs that have already become 20th-century classics."

"Les vraies questions sont:
- RÉSOUT IL LE PROBLÈME ?
- COMMENT SERA-T-IL VU DANS 10 ANS?
- SERT-IL? "

Charles Eames

"Charles Eames a été un architecte, un dessinateur et metteur en scène américain. Près a son épouse Ray il est responsable de nombreux dessins transformés déjà dans classiques du siècle XX."

DISEÑO
Design / Design

THE COLLEC- TION DESIGNERS



SIGFRIDO
Bilbao



JDM SEATING
Dept. Diseño

Un equipo multidisciplinar conforma el equipo del Departamento de Diseño: diseñador industrial, gráfico, infografista, fotógrafo de estudio e interiorista.

De esta manera el departamento plantea cada proyecto desde un punto de vista global en cuanto a desarrollo de producto y de comunicación.



PAOLO
Scagnellato



ANDREAS
Ostwald

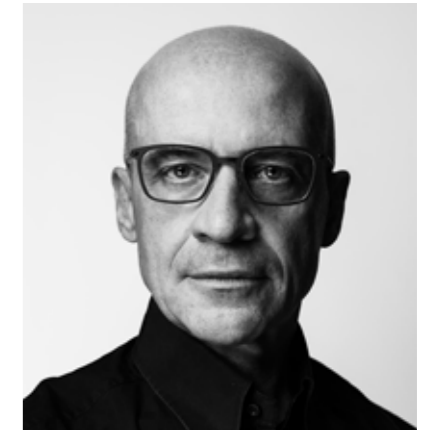

CLAUDIO
Bellini



JEREMIAH
Ferrarese



SI-DESIGN



GREY DESIGN
Studio



MASSIMO
Costaglia
ANGELO
Didoné

A multidisciplinary team makes up the team of the Design Department: industrial designer, graphic designer, infographic designer, studio photographer and interior designer.

This is how the department propose each project from a global point of view in terms of product development and communication.



ALEGRE DESIGN
Studio

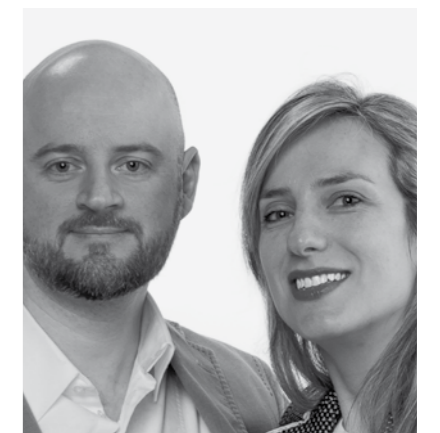

SABRINA
Bettini
STEFANO
Sandoná

Un équipe pluridisciplinaire forme l'équipe du département de dessin: Un dessinateur industriel, graphique, un infographiste, un photographe d'étude et un décorateur d'intérieur.

De Cette façon le département projette chaque projet d'un point de vue global en ce qui concerne un développement de produit et de communication.

THE COLLEC- TION

JDM
seating

Grupo Smobel

Estamos preparados.

We are ready / Nous sommes prêts.

AIDIMME
INSTITUTO TECNOLÓGICO
METALMECÁNICO, MUEBLE, MADERA, EMBALAJE Y AFINES



ECODISEÑO ISO 14006:2011

THE COLLEC- TION

JDM
seating

Grupo Simobel

Edición:
JDM SEATING

Diseño / Creatividad / Maquetación:
Sobreblanco Estudio

Infografías:
Sionstudio

SILLERÍA GENERAL CATÁLOGO TITON COLLEC- THE

JDM
seating

Grupo Ismobel

Polígono La Portalada II
C/ Cordonera 5
26006 LOGROÑO (La Rioja)
T. +34 941 230 752 / F. +34 941 248 977
ismobel@ismobel.com

ismobel.com



40 2021
1981

Grupo Ismobel



Communita^{MR}



Cuauhtémoc 158 B-I,
Col. Tizapán San Ángel
C.P. 01090, CDMX
Tels. 5512533780 / 5512533789
ventas@communita.com.mx
www.communita.com.mx

